

The Architecture of Methodism in Charlottetown

Reginald Porter



Charlottetown
2018

The Architecture of Methodism in Charlottetown

Reginald Porter

Charlottetown
2018

Copyright © 2018 by Reginald Porter.

This draft was completed on August 16, 2018, and fifteen copies were printed for distribution to various archival collections and interested individuals.

Further slight revisions were made to the text in October 2018.

Reginald Porter
8, Stewart Point Road,
Belle River, PE
C0A 1B0

regporter@bellaliant.net



The artwork on the cover is a detail of this 1864 watercolour by Robert Harris, and is found in the Confederation Centre Art Gallery, accession number 193.

Preface and Acknowledgements

Methodism and Charlottetown are both products of Eighteenth Century Britain. Just a generation before Charlottetown was laid out as a city of the Enlightenment, the Wesleyan Methodists were established to bring enlightenment to the poor and unfortunate classes by bringing the word of God to them. They did this in much the same way the early Christians had done – in private homes and open spaces.

When, by sheer force of numbers, the Methodists began to overcome official Church of England resentments, and began to build meeting halls, these structures were in the classical style of the day and tended to resemble temples. After it became possible to ordain Methodist ministers, these meeting halls came to be called chapels. Methodism was brought to Charlottetown with the arrival of Benjamin Chappell in October of 1778, but the first poorly-constructed meeting hall was only opened in 1816, replaced in 1835 by Isaac Smith's fine Greek Revival chapel on Prince Street.

By the late 1830s the Methodists in Britain were undergoing a very stressful time as, ever progressive, they were faced with the problem of whether they would build in the new highly-fashionable Gothic Revival style. Abhorring Gothic as Papist in nature, they eventually capitulated and accepted a form of Gothic inspired by Tudor buildings – hence Protestant in inspiration. What Thomas Alley designed in 1863 derived from those early models, in what is now known as the Nonconformist Gothic Revival style.

The Wesleyan Methodists were also committed to providing education for the young, beyond the study of Scripture. Elementary, and later Secondary, education became part of the Methodist programme. Neck-to-neck with similar efforts by the Anglicans and Catholics, various school buildings were built or rented as ancillary extensions of chapel architecture.

The realisation by this author that what happened in Methodist Britain was

paralleled by events in Charlottetown, led to the writing of this architectural study. It is an exercise in Art History. Obviously, in many ways it is also a history of Methodism in the city as much as it is a history of its various forms of architecture over the years.

This manuscript has been named *The Architecture of Methodism*, but it could just as easily have been called *The Landscape of Methodism* because it is in the artificially-created and measured landscape of the 18th Century Enlightenment that the first Methodists settled, and then began to build chapels and schools. Nearly all the early architecture of Methodism is now only known to us as fingerprints on historic maps, but because of the persistence of patterns in the landscape, we can visit all those sites and experience the Spirit of the Place.

There are kind individuals to thank, and we do so with great enthusiasm. First Katherine Dewar, who, after many discussions, focussed my interest on Trinity United and its history, and who arranged extensive access to the church archives and property. Dr. Austin L. Bowman, assisted by Rev. Greg Davis, provided terrifying access for photography and study, to the great forest that is the attic of the church. Carter Jeffery kindly produced plans of the brick church in various stages of its existence. Norman Carruthers brought Clifton United Church, a rare survivor of the early type of meeting house, to my attention and later arranged access to the building for measurements and a photographic survey.

I also express my gratitude to Ann Thurlow and Katherine Dewar, who kindly read the text critically. Their suggestions for corrections and clarifications were incorporated into the text, as were those of Dr. Doug Sobey and Gilbert Hughes, who kindly recommended clarifications in describing the original location of the New London settlement. Trevor Gillingwater offered suggestions to clarify certain details.

Illustrative material has been obtained from the Public Archives, the Trinity Archives, the collections of the PEI Museum and the Confederation Centre Art Gallery, and we are grateful for their generosity and kindness.

Table of Contents

Preface and Acknowledgements	3
Table of Contents	5
Prologue: The Island of Saint John and the Amazing Eighteenth Century	7
Chapter 1 Benjamin Chappell and the Arrival of Methodism in Charlottetown	15
Chapter 2 Isaac Smith and the Greek Revival	37
Chapter 3 Methodism and the Gothic Revival	53
Chapter 4 Thomas Alley, Mark Butcher and the Gothic Revival in Charlottetown	71
Chapter 5 The Later History of the Brick Church: 1873-1925	89
Chapter 6 Ancillary Architecture in Methodist Charlottetown	115
Epilogue	139
Appendix The Trinity United Church Years	143
Bibliography	163

Prologue:

The Island of Saint John and the Amazing Eighteenth Century

The 18th Century came to be known as the Age of Enlightenment as, more and more, the clouds of mediaeval thinking were replaced by clearly illuminated systems based on observable fact. For the first time the natural world – plant, animal and mineral – was classified in a way that is largely intact today. A passionate desire to discover and classify everything in the natural world gradually took over human consciousness and soon accelerated into a race to account for everything in the universe. No longer fettered by the reticence of the Catholic Church, very significant developments in optics led astronomers to an exploration of the heavens such as had never been possible before. The solar system as we know it began to emerge as planets and their moons were recorded with mathematical data. More powerful telescopes penetrated outer space and new galaxies, immeasurably distant, came into view. The crystal spheres of earlier centuries, to which all heavenly bodies were fixed, were smashed and blown away forever.

All human knowledge was classified, and the age of the encyclopedia was born when Chambers's *Cyclopaedia, or an Universal Dictionary of Arts and Sciences* was published in 1728. This was followed by the stupendous French *Encyclopédie*, by Diderot and D'Alembert, published in the years 1751-72, with royal second thoughts because of the fear (quite justified, as it turned out in 1789) of how so much knowledge might affect the ignorant masses. The English followed with the *Encyclopædia Britannica* in 1768. All knowledge suddenly became accessible to anybody who could read. Everywhere traditional towers of authority began to crumble and the race to know and understand everything in the universe was on.

Traditional Christian religious sects were understandably very alarmed by this new availability of universal knowledge, particularly the Church of Rome, which felt

that, for the most part, secular knowledge was of no use, and was indeed a great danger to the faith of their flocks, whose only instruction had to come from the catechism and the pulpit. The Protestant sects, heirs of the printing press that had brought the vernacular Bible within reach of all who could read, were less alarmed at this burst of knowledge. The Church of England, of which the monarch was the head, was content with a liturgy that increasingly had less and less relevance to the spiritual needs of its members. The great satirical artist, William Hogarth (1697-1764) produced a very popular engraving that was eagerly bought up, showing a “typical” Sunday service.



William Hogarth – The Sleeping Congregation, engraving, 1736.

In this vicious satire Hogarth depicts a congregation largely asleep before the pulpit that dominates the church space while the minister, with the aid of a magnifying glass, natters on and the clerk ogles the very visible bosom of a somnolent maiden. Room for congregations in Britain fell as the building of new Anglican churches declined in the 1700s.

There were many devout Christians who were appalled at the way things were going and sought remedies by refusing to take part in the practices of the Monarchy-oriented Anglican church. They were called Nonconformists and had Presbyterians, Congregationalists and Calvinists among their ranks. They sought a more direct way of communication with God, without the obstacles of the “official” church. This struggle for a simpler faith had begun after the Restoration of the British Monarchy in 1660 and was to continue, often in an atmosphere of sharp hostility from officialdom, into the 19th Century.

There was to be a new addition to the number of Nonconformist sects that would appeal to a very large number of disadvantaged people and eventually to members of the established classes. This came about in an unusual way. John Wesley (1703-91) was the son of a clergyman who went up to Oxford to obtain his degree. He was a pious young man and very sensitive to the large part of the population that led miserable Godless lives with no hope of comfort for the present and little thought of participation in life eternal.

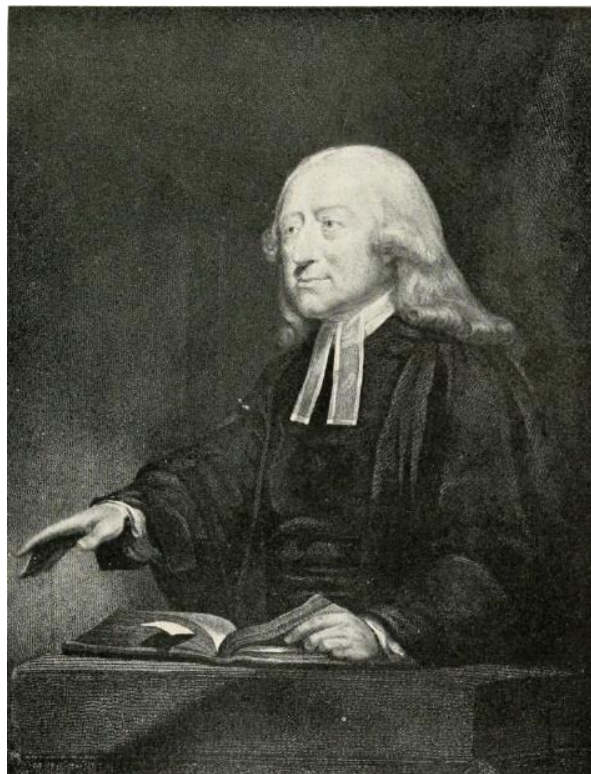

Wesley Preaching, engraving. n.d.

Wesley obtained his degree and was elected a Fellow of Lincoln College in 1726. To teach at college in those days it was required that one take Holy Orders and so in 1729 he was ordained a priest. His brother Charles had founded the Holy Club, a

society where members engaged in Bible study, prayer, and the pursuit of a good Christian life. The name “Holy Club” had been coined in derision by some of their Oxford contemporaries. As well, their carefully-structured prayer-filled days caused them to be called “Methodists” which Wesley and his followers seemed to have gladly adopted.

Wesley and his friends educated, gave religious instruction to, and prayed with the very unfortunate, often visiting prisons which at that time were hellholes of hopelessness. In time, they began to travel into the countryside and offered hope and practical skills to all those who came to them. In many ways Wesley and his followers were like the early Christians who met in private homes, discussed the words of Jesus and celebrated this fellowship with a meal – when it was available.

The movement quickly spread and both Wesley and George Whitefield, another Oxford friend, went to America where, usually on horseback and often in the open countryside, preached hope for salvation, not through Calvinist predestination, but through love and good works and kindly fellowship. A new religion was born and in its gentle, Christ-like approach to making the best out of life in all its manifestations, it was to provide, without a doubt, the most important, spiritually fulfilling and materially guiding search for the eternal for most of the 18th and 19th Centuries. Indeed, the world was the Wesleyan Methodist parish.

While John Wesley and his brothers in Christ gently wandered over ever-increasing parts of the English-speaking world, training un-ordained but devout followers to work among the miserable and unhappy as they did, rapid expansion on an international scale was taking place all over Europe and Eastern North America. England was fighting a seemingly endless war with France and Spain that is known as the Seven Years’ War. This war reached its culmination on the Plains of Abraham above Quebec City when General Wolfe and General Montcalm fought to the death, leaving the British in control of a vast unmeasured and unmeasurable empire in North America. The defeat was formalised by the Treaty of Paris in 1763 and the English lost no time in setting about to gain control of this largely unknown territory.

Accurate maps of these millions of square miles were badly needed to make successful plans. Of course, there had been map-making for centuries and the often extremely beautiful results of this work lay protected in heavy atlases or hung on the walls of collectors and adventurers. Beautiful they were, but accurate they were not, and could not be. It was the Ancient Greek geographers who first proposed the idea of latitude and longitude, a grid system that permitted mapmakers to pinpoint

any place in the world with a system of numbers and letters. Latitude was a system of lines that began at the equator and ended at the poles. Longitude was a similar system of parallel lines that, beginning at a fixed point called a meridian, ran north/south through the poles. In 1721 Britain established its own prime meridian at Greenwich, laying a brass line into the ground that provided a starting point for all future measuring and surveying. It was from this line, once the circumference of the earth became known, that distance measurements could be made so that a true grid of the lay of the land – or the ocean – could be constructed. In 1569 a Flemish geographer called Gerardus Mercator had produced a cylindrical map projection that, when flattened, gave us the grid system what we are familiar with today. Sailors were quick to adopt it because, using the grid, they could set a course, which when recorded, could be used by others to find places great distances away.

The 1760s was a time of great excitement and anxiety as astronomers and other observers tried to measure not only land distances but also celestial ones. There was one goal in mind and that was to produce accurate maps on which could be plotted real distances. This was especially vital in the largely unsettled wastes of North America. The British administration in Quebec immediately set to work to produce new maps. Although a perfectly accurate portable clock, vital in the calculation of longitude, was still in the stages of being invented by Thomas Harrison, work went ahead. A Dutchman called Samuel Holland, who had made a career in the British navy, and had fought at Quebec with Wolfe, showed surveying skills that were so great that he was able to measure and record distances more accurately than had ever been done before. As a result, the maps he produced, for the first time ever, had outlines that we recognise today. Holland was given the job of mapping all the territory from Quebec to the Potomac River. Because Royal favours were owed after the terrible expenses of the Seven Years' War it was decided to start with a survey of Saint John's Island, which was to be divided into as many 20,000-acre townships as possible, providing access to water for travel, and given away in a lottery to those to whom the Crown owed favours.

The guiding idea behind the whole project was to set up, on the Island of Saint John, a very ordered part of Old England with counties, parishes, townships and great estates filled with industrious tenants who would clear the land, help build the roads, grow amazingly productive crops and, with the greatest diffidence, pay their rent to the landlord or his representative. For the most part, this never happened, and the sweet dream of rustic prosperity in the New Land turned into the ugly reality, with few exceptions, of proprietors forgetting about the lots they had been granted and allowing chaos to set in as settlers exploited land without permission and supervision. With the help of a very corrupt administration,

were almost no citizens to fill this marvellous geometry with town houses. What there was lived for the most part in log or frame cabins, watched over by a weak, ill-equipped garrison and governors who were incompetent at best and cruel greedy thieves at worst.

And yet in all this was a grand plan. It is possible that the Island was the first territory in the world that was accurately surveyed so that the map, for the most part, represented it in a way no one had ever seen – with an exact outline and known acreage. And for the most part it was possible to locate any land grant and, with minimal surveying skills based on the Magnetic North of 1765, carve out a property whose boundaries would be respected hundreds of years later. Incredibly, this happened all over the Island so that in one hundred years all the land had been mostly equitably divided and property lines set up that exist to this day. Every square inch of Saint John's Island was accounted for and had a name attached to it. There were few wildernesses, only the sublime lines drawn by minds whose only useful guidebook was a treatise written by an architect called Vitruvius, who lived at the time of the Emperor Augustus and, coincidentally, the time of Jesus Christ. Ideas taken out of Vitruvius' *Ten Books of Architecture* had been incorporated into various guidebooks prepared for the surveyors of the New World. In this way the surveying of the Island of Saint John was influenced by Roman ideas of town planning and the exploitation of landscape for settlement.

It was to this land in a new world, and to the city of Charlottetown modelled on the lines of a Roman legionary camp, that Methodism would make its appearance, and stay, and flourish so magnificently that its very presence inspired the course of architecture not only in the city, but in the province as well. It is in this world that the apostle of Methodism, Benjamin Chappell, beloved friend of John Wesley, would begin his mission.

Chapter 1

Benjamin Chappell and the Arrival of Methodism in Charlottetown

Sometimes it chances that circumstances conspire to cause unrelated events to combine in such a way that elements of an era are defined in the most amazing manner. Such a situation came together in the last decades of the Eighteenth Century when an Englishman, with no connections to Saint John's Island, found himself as an indentured servant in a Quaker colony at Grenville Bay (later New London Bay), at 34 years, in the prime of his life, and with a young wife who was expecting a child. This man was Benjamin Chappell and, in a few years, after the new settlement foundered, he would move to Charlottetown in 1778 and there, with colleagues, would establish a Wesleyan Methodist community in a largely unsettled city, beautifully planned, but still a wilderness. After years of meeting in his home he would live to see his dream of a chapel come true, the first in what would be several impressive Methodist places of worship in the city.

Benjamin Chappell was born in London on March 5, 1740/41. He became a skilled worker, called in those days a mechanic, with abilities as a wheelwright and machinist. In the 18th Century period of the Industrial Revolution, a machinist, by definition, was a person who repaired the many kinds of machines that were the backbone of this new age of manufacturing. He would be skilled at replacing wooden parts, possibly with the use of a lathe, but would also be skilled at forging and shaping metal when it was needed. The machinist was the person who helped design the new mills that ran the new industrial age and was the person who directed the building of those often-complicated apparatuses that made the mills run. The skill of the wheelwright was also highly-desired at a time when road construction and communication were peaking in Britain for the first time since the Roman era, and there was a constant demand for new kinds of carriages and wagons as well as all the maintenance work required to keep them on the rutty and often dangerous roads. All these things Benjamin Chappell did, and he exercised

them all in new environments in a New World.

Early in his life Chappell became attracted to the kind of Christianity that was practised by various Nonconformist groups such as the Wesleyan Methodists. He was drawn especially to the preaching of the Wesley brothers, John and Charles, whose design for salvation was a practical combination of elements that brought the convert to God but also brought him in contact with a strong desire to educate the working classes not only in Faith but also in many practical skills that could advance a person in life. Before 1770 Chappell met the Wesley brothers at Islington which was a district in Inner London. He managed to learn and use his practical skills while following the Wesleys about, and in April 1770 Wesley, writing in his journal of his visit to Inverness in Scotland, said, “Benjamin and William Chappell, who had been here three months, were waiting for a vessel to return to London. They had met a few people every night to sing and pray together; and their behaviour, suitable to their profession, had removed much prejudice” (Bumstead DCB).

In the summer of 1774 Chappell, with his wife Elizabeth whom he had married in February, set sail on a scow, also called “Elizabeth”, for the Island of Saint John, where he was indentured to the founder of a new colony for a period of four years. We don’t know why the Chappells left London at this time to go to a place of which they had only hearsay knowledge. Bumstead (DCB) cites problems of unemployment at that time and that might have been the reason for their departure. Somehow, Chappell knew the merchant who would found this colony and was probably persuaded by him, in a fit of enthusiastic rhapsodizing, that there was a great future in being part of a town that would harvest, and mill lumber and send it, along with some fish bought from fishermen, to the West Indies in return for sugar, hard cash and of course, rum.

The new settlement, in what was named Grenville Bay by Holland, was called New London. As depicted in 18th Century engraved maps based on the Holland survey, it was established on a street or road on the west side of the bay, running parallel to the shore about a half-kilometer inland, and Elizabeth Town, a little further south on the other side of the French River, that could not at that time be bridged. Much further down, southwest on a branch of the Stanley River, a sawmill was built. Somehow Holland seems to have missed the Southwest River entirely as it does not appear on his map. As observed by Lockerby and Sobey, Holland’s survey frequently did not penetrate any distance inland. Few individuals, except for the Acadian settlers who had avoided deportation, knew the lay of the land.

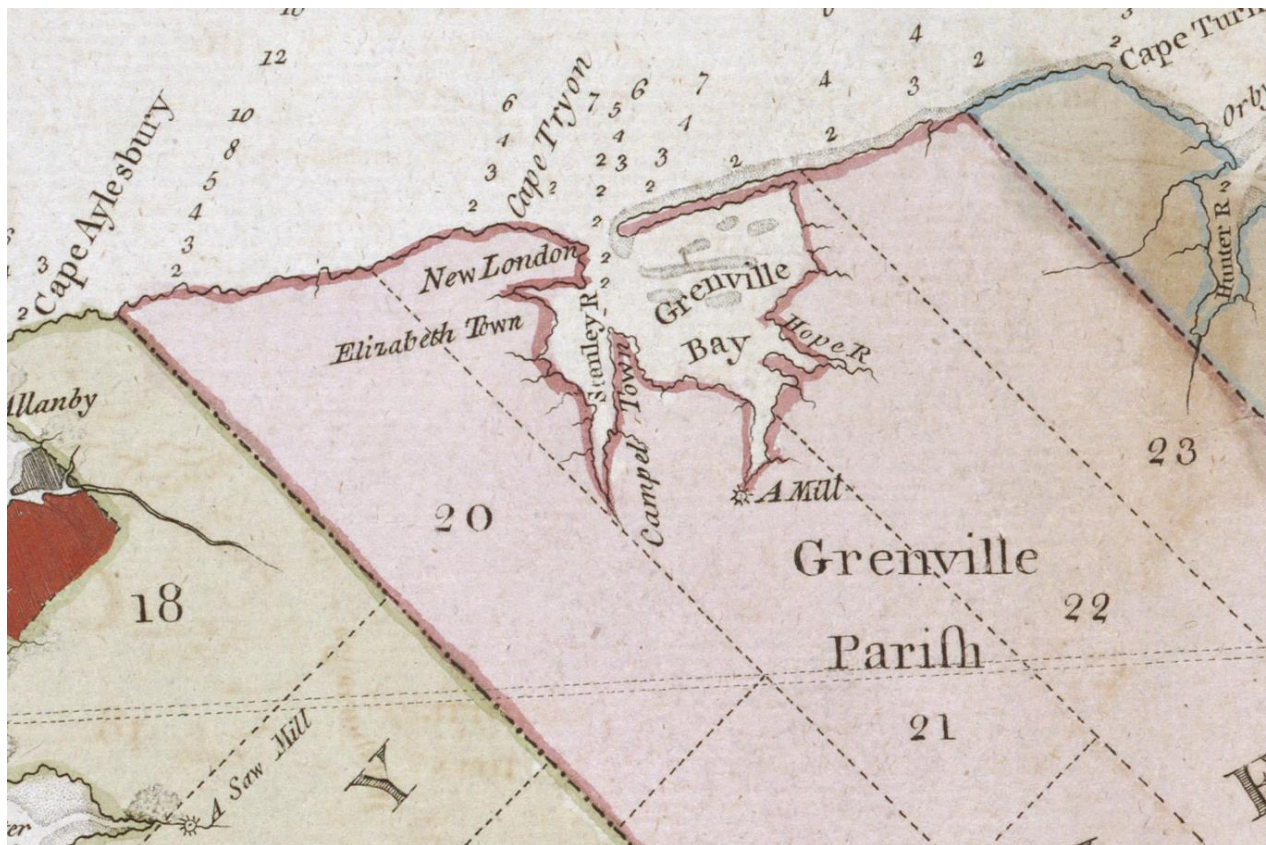

Detail of Dury – Map of the Island of Saint John, 1775, showing Lot 21 and, mysteriously on one of the earliest printed Holland maps, New London and Elizabeth Town clearly named. Porter Collection.

Nearly all the settlements that appear on the Dury version of the engraved copper plate map are optimistic fictions such as Desbrisay Town and Stawell Grove in Lot 33 and Parnells Grove and Maryborough Town in Lot 31, to name but a couple. But – and here is the mystery – around Grenville Bay we find three settlements and a mill that really did exist, and which were established, at least theoretically, in 1773. The question is: where did the map seller Dury get this amazingly up-to-date information about these new settlements and how was it arranged that the names be engraved on the copper plate for the next print run? The map itself would only become available in 1775. It is the first real evidence that reality has begun to replace pipe dreams in the settlement of the colony and Clark's brave Quaker experiment, immortalised on a map, is at the beginning of it all.

Looking at the most attractive outline of Grenville Bay an investor could be easily taken in by what it seemed to promise: a not-too-big bay for harbours and anchorage, easy water transport to (yet unimagined) inland towns and massive protection from the blasts of the sea by miles of huge barrier dunes.

The reality, of course, was vastly different. Because of ever-changing patterns of silting the harbour mouth was so shallow as to afford sufficient depth – only two fathoms – for only the smallest of boats. The Dury map clearly shows that the Bay is filled with dunes and shallows. Large sea-going boats, that were to be the life and soul of this business enterprise, had to be anchored out in the Gulf of Saint Lawrence where they were vulnerable to every storm that blew up in the Gulf. All goods and materials had to be ferried to their various destinations in the settlement by means of small shallow boats.

The great dreamer who had such wonderful plans for his new town was a devout Quaker, Robert Clark and the third owner of Lot 21 in seven years. He, and his business partner Robert Campbell, had money and access to good credit and could buy everything that was necessary to set up three towns and the sawmill. He did not enter this adventure sight-unseen. In 1772-73 a colleague and friend of Clark's, James MacDonald, came to Grenville Bay and determined where the settlement and the mill would be located. He also became painfully aware of the severe limitations the entrance of the bay had as a potential harbour. Nevertheless, he set about, as the first settler of Lot 21, to establish Elizabeth Town as his home base, named not, as romantic legends surrounding Benjamin Chappell suggest, after Chappell's wife, but after Clark's wife Elizabeth who had died in 1771. The story of Clark's great dream has recently been told in John Cousin's book, *New London: The Lost Dream – The Quaker Settlement on P.E.I.'s North Shore, 1773-95*.

In the summer of 1774, the brig Elizabeth (yet another Elizabeth to confuse issues!) arrived filled with necessary supplies and all the highly-skilled workmen required to put this dream of industry in the New World into motion. Among these skilled workmen was Benjamin Chappell who, according to Cousins, quickly moved up to the New London site to help build a series of tenement buildings on a street running along the shore where the 129 settlers, except the people who ran the mill, and MacDonald and Campbell, would live. There was much to do before the first winter descended and house construction was still going on in January of 1775. It was an appalling first winter but somehow, with the potatoes and fish available, there seems to have been no starvation.

Things did not go well for this settlement. A new ship, filled with valuable provisions and supplies, was wrecked in the fall of 1775. This was a major disaster and a tremendous financial loss. Clark had foolishly lent large sums of money to Governor Patterson, and to others in his administration, all of which he was to lose. The *coup-de-grace* was the beginning of the American Revolution in 1776, cutting off all communication with the West Indies and subjecting the Island of Saint John

to raids by privateers from the rebel colonies. Charlottetown – all 15 households of it – was sacked and the administrator and instruments of administration taken away. This business venture lasted until 1795 when it was given up as a lost cause and the principal investors began to develop parts of other lots which they had acquired.

There is an account of Chappell's religious activities in New London given by Mellish (pp. 3-4) which gives us a good idea of how he practised his faith in the friendly Quaker environment:

Not a vestige of Elizabethtown now remains, except the burial ground; but old people are still living at New London who remember when a long row of houses, all in ruins, were to be seen between Yankee Hill and the burial ground in Mr. Sims's field. Elizabethtown is marked in maps published in London as late as 1830. Constant oral tradition affirms that Mr. Chappell was accustomed to conduct religious services in this village, where he resided for several years. A projecting rock on the bluff-head, known as "Chappell's Chair," is pointed out as the place where he preached or held these services. Under date March 1775, he refers to this spot as his "Elysian seat," in his diary. This diary or journal contains most interesting information regarding both the religious and secular early history of the colony for more than forty years. Unfortunately, one volume of the journal, and Mr. Chappell's letter book, have been lost. Only one scrap of a letter remains, dated October 1775; it was addressed to a Mr. C. of Newcastle, was written "From the Island of St. John in the Gulf of St. Lawrence," and concludes, "For my own part, we hope to labor, working with our hands the thing that is right, for hitherto hath the Lord helped us – and to read our Bible to good purpose till we rest from our labors." In the spring of 1775 Mr. and Mrs. Chappell were in doubt as to whether they would remove from the Island, but on June 9th he records that they concluded to remain and trust in God.

Benjamin Chappell had seen the writing on the wall and when his period of indenture to his master and friend Robert Clark expired after four years he lost no time in moving to Charlottetown in October of 1778 to start yet another new life. His infant daughter – yet another Elizabeth! – had recently died.

We are not sure what connections Chappell had made in Charlottetown that would make his move there seem like the best thing to do. In the previous four years, he would no doubt have heard about or met the people who tried to provide the

inhabitants of the city with wheels and carriages for transportation and even pumps for the public wells located around the city. He might have built some of the better houses going up in the city and perhaps worked in the construction of the batteries for the military.

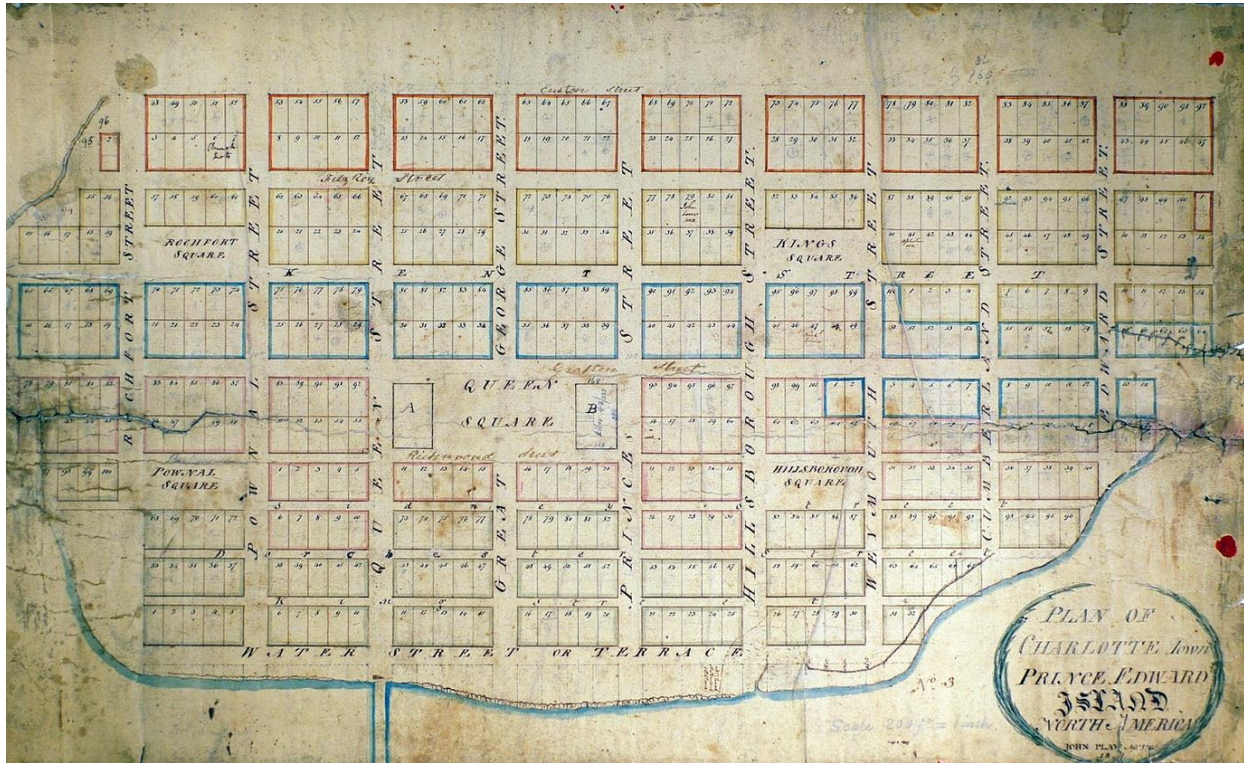

The city Benjamin Chappell would have known. John Plaw Map of Charlottetown, 1817. PARO

Charlottetown in those days was a miserable place with most of the streets still not opened and swamp and forest filling the whole of the boundary set out by Charles Morris in 1768. Holland had chosen the site for Charlottetown with the brilliance of a naval commander utterly familiar with the defense of towns in 18th Century naval warfare. The city that would be laid out would have a central square where the soul, the stomach, the mind, the need for justice and the place of Government would all be housed. Other green areas or squares were later inserted in the four quarters of the city and can be seen in the Plaw map. This would be the city that Chappell would make his home for the rest of his life.

Maps, the glory of cartographers, are beautiful things on paper but the reality on the ground is another matter. For years the site of Charlottetown would be a wilderness of forest, swamps, streams and stumps. The streets would have to be surveyed in the most exact way and crews of workmen hired to cut the timber, remove the stumps, drain the swamps and divert the streams. It is interesting to

note that Arsenault and Lockerby (2016) have recently published articles that demonstrate that Acadians, who had re-established themselves on the Island after the deportation, were sought out and hired to do the clearing.

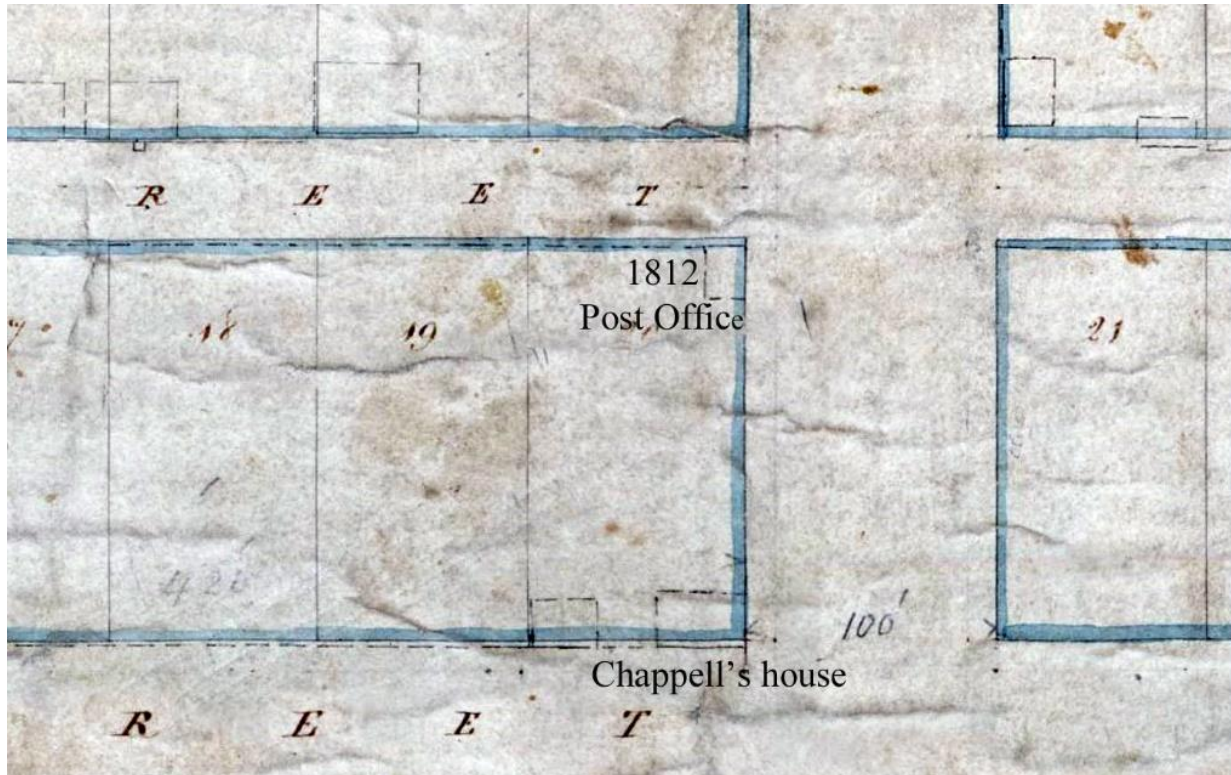

Detail of the 1833 Wright Map showing the encroachments on the streets of Charlottetown. Benjamin Chappell's home was on the southwest corner of Water Street as it borders Prince Street. It also shows the separate Post office he built in 1812 on King and Prince Streets. PARO.

By the time Benjamin Chappell died in 1825, he would have experienced first-hand the conditions of disarray in the lines of the city streets as they had evolved since the time of Governor Patterson in the 1770s. In 1833 things were so bad that Governor Young commissioned the chief surveyor, Thomas Wright, to produce a huge map of the city called "Charlottetown, shewing the true positions of the Streets and the encroachments thereon" at a scale of 80 feet to the inch. This map, now in the Public Archives, is the most important guide in existence for the study of the evolution of Charlottetown, the regularising of its streets and most probably showing the location of all the buildings standing at that time.

It was here that Chappell found a place to stay, in the relatively cleared-out part of the waterfront that was still very close to Queen's Square, the heart of the city. Here he bought a house and in 1802 became Post Master. In 1807 he lost the job for a few years, but when he regained it in 1812, he built a small post office at the

north end of his lot. These structures can be clearly seen on the detail of the larger map illustrated above, His tenure as post master, a juicy plum in city employment at that time, was not without its ups and downs as Alison Ann Heckbert describes in the *Island Magazine*, 1990:

Although Charlottetown had no postmaster until 1800, this is not to say that no one had been responsible for the mail. In 1787, Lieutenant Governor Fanning appointed printer James Robertson to look after his dispatches and such other mail as turned up. On Robertson's departure in 1789, another printer, William Rind, was given the appointment He probably handled the mail from his printing office. John Ross (listed elsewhere as Clerk of the Council) succeeded him about 1798. Ross received official recognition on 23 July 1800 when he was appointed “Deputy Post Master” by George Heriot, the newly appointed Postmaster General of the Provinces of Canada, Nova Scotia, New Brunswick and their dependencies. Ross died on 2 May 1802. The following day, 63-year-old Benjamin Chappell, craftsman, Methodist lay preacher, and diarist, was named deputy postmaster on an acting basis, an appointment confirmed by Heriot the following October. Chappell, not Ross, is now remembered as the Island’s first postmaster. The office of postmaster is usually said to have remained in the Chappell family for the next 40 years. In fact, this was not so. The position was a very small plum in a colony full of office-seekers, but a plum nonetheless, and it changed hands several times during the decade following Chappell’s appointment. Although information about the appointments is sketchy and sometimes conflicting, it appears that Chappell was replaced in 1807 by James Chalmers. By 1809 Chalmers had given way to the flamboyant John Frederick Holland, a local politician and multiple office-holder. . . . After Governor DesBarres’s recall, Administrator William Townshend restored Chappell to his post in November 1812, ending the merry-go-round of appointments. Thereafter, the Chappells did dominate the postmaster’s job.

The post office was initially situated in Benjamin Chappell’s own home on the northwest corner of Prince and Water Streets. Chappell had another building constructed on the rear of this property, facing King Street, and apparently moved the post office into it around 1812.

A drawing by Arthur Newbery, done circa 1836-40, shows us what Chappell’s house looked like. It was built of logs laid horizontally with corner boards applied to protect the morticed joints from the effect of the weather. There seems to be a winter porch over the central door and shed dormers match the windows on the

ground floor, thus bringing regularity to the house, a quality not uncommon in a city where even small houses adhered to Georgian symmetry in their design.



Arthur Newbery, "General Post Office Prince Edward Island from 1766 to 1836. PEIMHF.

This quote from Benjamin Bremner, *An Island Scrapbook*, gives us an idea of how this tiny cottage with its enormous weathervane in the shape of a fish, affected the local population,

Mr. John Morris, in answer to a question put of him regarding Prince Edward Island and what old people he remembered in Charlottetown, when a boy replied: "I recollect old Mr. Chappell who kept the post office. He had a board the shape of a fish on his house over where he slept and at the end of the board was another which turned around and indicated the way the wind was blowing and by this he could tell when the wind was fair for the packet."

And what about those 16 years in Charlottetown before the not-very-demanding job of Post Master fell into his lap? What did Chappell do? He had obvious skills

as a mechanic and wheelwright brought from Britain and he had four years of having put every aspect of them to the test in the rigours of the New World. At New London, it is not very likely that his skills as a wheelwright would have been in much demand. Building houses and furniture, the complicated mechanical requirements of mills and the technicalities of dams would have occupied most of his attention. In Charlottetown however, where a semblance of streets was emerging and roads to Princetown and Saint Peter's were being opened, there would have been an increased demand for wheels, wagons and carriages. Chappell was probably very busy at those activities during those years. He also became involved in making spinning wheels and so numerous were his commissions that soon, we are told, he began to stamp serial numbers on them.

But most of all, Benjamin Chappell was a devout man, a good man in every way, full of memories of missionary work in Britain under the direct guidance of John and Charles Wesley. It seems that he began his religious activities almost as soon as he arrived in the city. A letter quoted in Mellish (page 5) suggests that he was well-known and much in demand as early as his arrival in 1778:

Mrs. Richardson presents compliments to Mr. and Mrs. Chappell, and begs the favor to know if Mr. Chappell reads prayers this evening, and what time, as she would be happy to attend.

Benjamin Chappell cared deeply about the spiritual well-being of the people he worked with and this caring had its origins in activities of early Christians as described in the Gospels. One such story is found in Chapter 9 of the *Acts of the Apostles*, just after the conversion of Saul. It concerns an account of a woman called Dorcas who spent much of her time seeing that the naked were clothed.

The story of Dorcas was dear to the Methodists as it illustrated a practical Christianity that could be practised for the good of the community. We can easily imagine Benjamin Chappell looking around the city and, with other like-minded neighbours, performing such corporal works of mercy. Increasingly groups of people began to meet at Chappell's house for readings from the Bible, the singing of hymns from Wesley's great hymnal and perhaps even sermons that attempted to develop the urgings of Jesus in the New Testament to seek a better life and to love your neighbours.

It was in this way that Methodism took root in Charlottetown and which was, in the years ahead, to have such a profound influence on the development of architecture in the city.



Detail of engraving of Rev William Black. Library and Archives Canada-MIKAN 3021765.

As time went on Chappell urgently tried to obtain the services of a Methodist minister so that his group of followers could be formally accepted into the faith and be able to receive communion. We have an account, (Mellish p. 5) of the first disastrous visit of a minister to the city.

Under date October 20, 1783, the Rev. William Black, of Nova Scotia, makes the following entry in his journal: "I set off for the Island of St. John's, at the earnest and repeated invitation of Mr. B. Chappell, where I arrived on the 22nd, and tarried about a fortnight. I preached several times at Charlottetown and St. Peters; but alas! the people in general appeared stupid and senseless as stones, altogether ignorant of the nature of true religion, and of that faith which worketh by love." This was the first visit of a Methodist minister to the Island.

William Black began his life in Yorkshire and in 1775 joined a great stream of immigrants that settled in the Tantramar Marshes in the Isthmus of Chignecto. Black settled with his parents near Amherst, Nova Scotia and seems to have spent

his youth in riotous living. A great many of the Yorkshire settlers were Methodists and held prayer meetings in their homes. Black attended some of these, perhaps because there was nothing better to do, and at one of these gatherings in 1779, underwent a spectacular conversion. Thus, began a new period in Black's life and he began to lead prayer meetings and eventually, guided by the Wesleyan principles that surrounded him, he began to preach extensively all over Nova Scotia and the Chignecto area of New Brunswick (DCB).

In 1794 he returned to Charlottetown, met the Anglican minister Theophilus DesBrisay, and was given by Governor Fanning the use of the first small Anglican/Presbyterian church that had been built on the west end of Queen's Square. This is how Black described the event:

At Charlottetown Mr. Black met with a pleasing reception. "I waited," he says, "on the Governor, Col. Fanning, who received me kindly, expressed himself in terms of commendation respecting Mr. Wesley and his people, and gave me the use of the church. The Governor's Secretary and the Attorney-General attended preaching in the evening. Sunday, 12th October, I again preached twice in the church to a large congregation. At eleven o'clock I had the pleasure of hearing the Rev. Mr. Desbrisay, the clergyman of the town. He delivered a plain, honest discourse ... On the 13th I had a friendly visit from him. It is my desire to cultivate a Christian friendship and all proper union with the ministers of the Church of England. I waited on His Excellency to present my acknowledgments for the use of the church. I spent nearly an hour with him very agreeably; we conversed freely on the advantage of religion to individuals and society in general. He expressed much friendship, and offers to assist us if we will erect a chapel in town." (Rogers, p. 15)

This was a very significant moment for the small group of Methodists in Charlottetown, but it would be some years before the project got underway.

More Methodists began to arrive on the Island in 1806 and settled in Guernsey Cove and Murray Harbour where they would eventually build a chapel.

It was a happy day for Benjamin Chappell and his Methodist friends when on August 1, 1807 James Bulpitt, the city's first ordained minister, arrived in Charlottetown. Bulpitt was a native of London, born in 1767 and began his work as a preacher and was ordained in 1799. Chappell joyfully recorded the event in his journal.

“Aug. 1st, 1807.— Mr. Bulpitt was in town last night; the first night.
 “ 5th.— Mr. Bulpitt preached for the first time; on John 14 : 6—‘I am the way, and the truth and the life,’ &c.
 “9th.— Mr. Bulpitt, on ‘Enoch had this testimony, that he pleased God.’
 (Mellish p. 12)

Everything seems to have got off to a good start.

The Governor received the new minister with kindness, inquired whether the Methodists would fight for the king, and allowed him to preach in the Court House or the unfinished church, where a large congregation of the most respectable inhabitants listened to him. The rector, who officiated in the morning, attended the Methodist services with his family, in the evening; and his eldest son soon became a member of the class. Soon after his arrival Mr. Bulpitt reported the number of members of society as fifty, fifteen of whom were resident in the town. There was preaching on Wednesday evenings at Theophilus Chappell’s house, and sometimes at his father’s. Prayer meetings were held on Sunday mornings in the large room of Mr. Bulpitt’s house, where Mrs. Bulpitt conducted a day school on week days. Mr. Chappell canvassed the town for subscriptions towards the new minister’s salary. (Mellish pp. 12 and 13)

By August 10, 1808 Bulpitt has good news to report to Rev. Mr. Lomas of the Missionary Committee:

‘After one year’s labour I think I can ascertain, with some degree of accuracy, the possibility of usefulness in this Island. In your last letter you express an hope that my expectations may be realized. In part they are, but not so rapidly as as (sic) I thought at first.

After much mature deliberation, some of the respectable inhabitants of this town have come to a determination to build a chapel for the use of the Methodists, and a dwelling-house for the preacher. The chapel is to be 40 by 30 feet. The timber is cut and brought to the place for framing. In the meantime the Governor and gentlemen of this place have been so kind as to favor us with the use of the Court House, in which we meet twice a week.



Wright, George, Detail of an 1833 manuscript map of Charlottetown, recording encroachments in the city plan, which shows the location of the 1816 chapel on Richmond Street, with its 1821 Mission House next to it. PARO.



Present site on Richmond Street, between Queen and Pownal Streets, where the first chapel and mission house were located.

Significant progress towards erecting the first chapel was made in Charlottetown when Benjamin Evans, a merchant, gave a valuable piece of land very close to Queen's Square.

The arrangements made in 1808 for building a chapel were not carried out at the time for various reasons. The Rev. J. Knowlan from Nova Scotia arrived at Charlottetown September 28, 1810, and remained about a fortnight. He preached several times, and assisted in completing the purchase of "All that piece or parcel of land lying and being in Charlottetown aforesaid, being the eastern moiety or full equal half part of Lot No. 53 in the 2nd hundred of town lots in the said Town, which said land and premises, by deed dated the 5th of October, 1810, was conveyed by Benjamin Evans, merchant, to Joseph Robinson, Thomas Desbrisay, the younger, Joseph Avar, Thomas Murphy and Paul Mahey, and to their heirs and assigns, in trust, for a preaching house and conveniency as shall be judged necessary for the benefit and accommodation of the society of people called Methodists, at Charlottetown." This site was on the north side of Richmond Street a short distance west of Queen Street, near the "London House" corner (Mellish pp. 14-15).

Rev. Bulpitt's appointment ran out and was not renewed. This caused much bitterness:

Mr. Bulpitt expected to be recalled after three years' service, but the Missionary Committee did not accede to his request. He therefore refused to acknowledge the authority of the Nova Scotia Conference, and thenceforward maintained the position of an independent minister. He continued to travel through the country and preach at the various settlements. His name is still mentioned with great respect by many of the older inhabitants. He owned the house where he lived, which adjoined the chapel. On the death of his wife in 1842, Mr. Bulpitt removed to Crapaud where he died at the residence of his son, James Chancey Bulpitt, December 20, 1849, in the eighty-third year of his age. (Mellish p. 15)

For reasons which are unclear, things did not go as planned in building the first chapel and it was not until the arrival of Rev. John Hick and his wife, sent out by the British Missionary Society from Yorkshire, arrived by ship on April 23, 1815 that real progress was made. In the next three years, he would see to the construction of the chapel, with the assistance of the military, and his letters give us an affectionate view of the aging Benjamin and Elizabeth Chappell.

“Since the erection of our chapel in Charlottetown we have had a great accession of hearers, especially on Sabbath evenings. It was supposed by many when we began to build that the plan was too expensive for the size of the place; and I must confess it was my opinion that a chapel on a smaller scale would have been sufficient to contain the congregation; but when it was opened, such was the desire of the inhabitants to obtain pews that I am convinced if we had built a smaller we should have done wrong. We have in Charlottetown a member in society by the name of Benjamin Chappell, who is mentioned with respect by Wesley in the fourth volume of his journals, page 439, and with whom he maintained a correspondence until he was taken to his exceeding great reward. He and his wife have been on the Island for nearly forty years. They both appear to be ripening fast for glory. I will assure you that I frequently get my soul blessed while in converse with them, and in hearing them tell of the wonders of redeeming love in the conversion of sinners in the infant days of Methodism.

So, by August 1, 1816, the date of this letter from Hick (Mellish p. 17), the chapel was finally completed to the point where it could be used for worship. Some doubt as to the quality of its workmanship is cast in an account found in the *Royal Gazette* of Tuesday, July 21, 1835, when the second chapel, designed and built by Isaac Smith, was being discussed. The article says, “nineteen years ago in Charlottetown the friends of Methodism laid the foundation of their first place of worship ‘small and feeble was their day’. Owing to causes to which we shall not refer here that place of worship was never finished . . . to repair and finish it was a waste of money and labour . . . so a new edifice was projected.”

We might ask what this first chapel looked like. Our only information about it consists of the outline in Wright’s 1833 map and the fact that it was 30x40 feet. The map shows that it had a porch. It was referred to both as a chapel and a mission house. That was not unusual in early Methodist times as meetings were first held in private houses and would continue to be for at least another century until Methodism spread and became so strong that chapels were swiftly built in many towns and cities. Perhaps the closest surviving example of what that church would have looked like can be seen in the 1848 Clifton United Church at Southport (see p. 33).

We will digress briefly to discuss the evolution of Wesleyan Methodist chapels in the 18th Century. When John Wesley began his ministry, he did so as an Anglican priest who had become part of several Nonconformist sects that were not welcome in most Anglican churches where a strict order was maintained in the performance

of the services. The Methodists were more relaxed in their worship and this was enough to cause them to be looked upon with suspicion, even of plotting against the established order. As a result, the friends met in private homes or, as Wesley travelled across the countryside, in the open with the preacher often using his horse as a pulpit.

In the years ahead, structures built or adapted for Methodist meetings tended to be very un-church like. Almost anything would do. As the need for buildings multiplied Wesley became fascinated by the possibilities of the octagon as an ideal space for a congregation to gather to see the preacher and hear the words of salvation from every part of the church. Although he encouraged this among his followers only a few, just over a dozen, were ever built in the 1760-80 period. In these little octagons the pulpit was generally placed in a raised position against the balcony rail that surrounded the whole building. This would become a convention in Wesleyan churches.

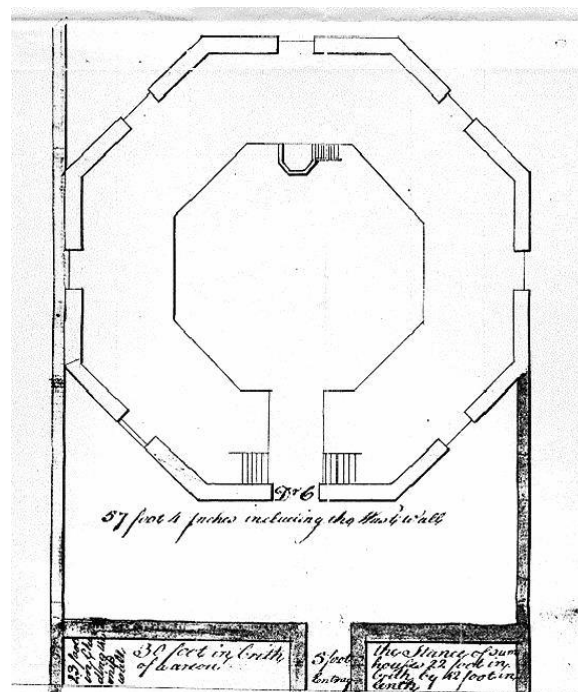

In the plan of the little octagonal chapel built in Edinburgh in 1765, the pulpit was placed in a raised position against the balcony rail that surrounded the whole building. (Dolbey p. 110)

Windows in each facet of the octagon provided light to illuminate the preacher, high in his pulpit, but also the congregation located at both levels. The octagonal

idea did not take hold in the popular imagination and so only about a dozen such structures were ever built. A few still survive.

The new form of the Wesleyan Methodist chapel was a rectangular building enclosed with classical architectural elements such as columns and pediments that resulted in buildings that looked like ancient temples. However, as much as possible, the desire for the audibility and visibility of the old octagons was kept and every effort was made to have the preacher both heard and seen from every pew in the chapel.

This ideal of the best possible communication in a chapel is expressed in this old engraving, so full of drama, that shows, in Wesley's splendid City Chapel in London, the preacher in his high pulpit, visible and audible to the whole congregation.

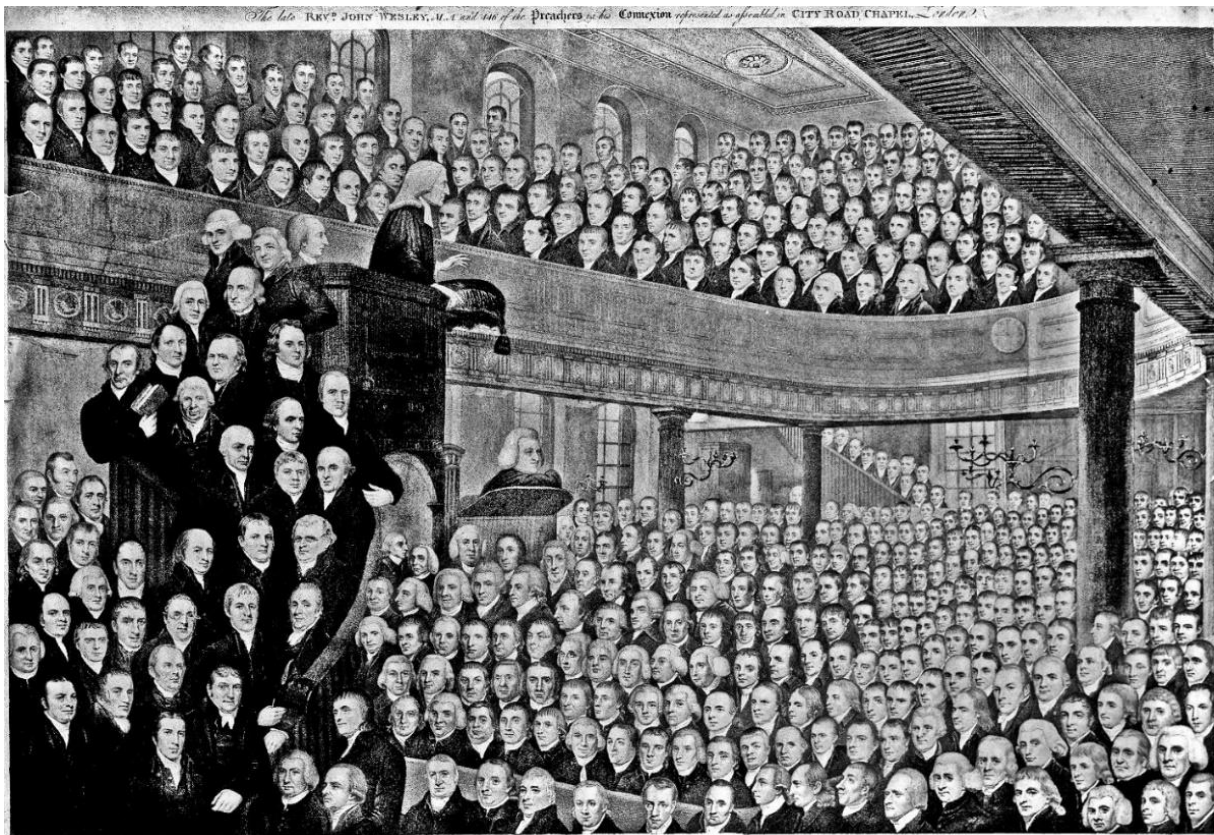

John Wesley preaching in the City Chapel (now Wesley's Chapel, London). This picture gives an idea of the direction in which the design of Methodist chapels was evolving. The Methodists believed that every member of the congregation should be able to see and hear the preacher, wherever they were in the chapel. Engraving by T. Blood – 1822.

By the late 18th Century the Wesleyan Methodists had, for the most part, adopted

this kind of classical design that reflected the Georgian-inspired styles then in vogue. The buildings were rectangular and nearly always had a classical temple front in the Doric or Ionic styles. Generally, incorporated into the structure or added at the side or back, was a house for the preacher and often classrooms for the educational programmes that were so dear to the Methodists.

When we return to the possible appearance of the first Methodist Chapel in Charlottetown we have only the outline on the Wright map to guide us, but that is enough to allow us to reconstruct what the building might have looked like. Although described as unfinished and unsightly in a later account, the chapel would have appeared to us today as a stylish structure with elegant window and door frames and large corner boards emphasising the classical temple inspiration behind the structure. Two early buildings from a generation later, and incorporating decorative elements of a new style, nevertheless give us an idea of that first chapel.



First Baptist Church, Crossroads, (now Church of Christ), 1836, PARO.



Wesleyan Methodist Chapel (now Clifton United), 1848-49, Bunbury.

It would be interesting to discover who designed the Methodist chapel on Richmond Street. John Plaw (1746-1820) a famous architect of the Picturesque movement and author of three beautifully illustrated books on elegant country dwellings, moved to Charlottetown in 1807, probably to escape creditors and a failing business. He lived there until his death in 1820. Could Plaw have had a hand in designing the chapel? Perhaps, but it is more probable that one of their own, Benjamin Chappell, who by now had a great deal of experience in building, and who had seen many Wesleyan Methodist chapels during his years in England, would have provided the design. He may even have supervised its construction.

In 1821 a Mission House was built:

The Rev. Stephen Bamford was first appointed to the circuit in 1821. We are told that “He laboured faithfully, secured the affections of the people, and made considerable provision for the erection of a Mission House,” which was erected at the back of the chapel (Mellish p. 20).

In Mellish’s account this is described as having been built at the back of the chapel but in Wright’s 1833 plan the only other building on the lot is to the left of the chapel. We may assume that this is the house in question. What would it have looked like? It was a large two-storey house, about 20 by 40 feet. All the odds are that it was a simple central plan Georgian house that, judging by its size relative to the chapel, probably had five bays with two windows on either side of the central doorway and corresponding windows on the second floor. It is sometimes confused with the house in which Mrs. Bulpitt set up her school, but that was some years before this Mission House was built. There still exist in Charlottetown several such simple Georgian houses from that period, and a small house at 100 Prince Street, built by Isaac Smith and his brother in 1827, gives us an excellent idea of what the Mission House would have looked like.



Isaac and Henry Smith – Five-bay house at 100 Prince Street, built in 1827. The 1821 Mission House on Richmond Street would no doubt have been more or less identical.

This then, is the story of the architecture associated with the earliest organised Methodist presence in Charlottetown. The central character is Benjamin Chappell and there is no better fitting conclusion to this first chapter than his obituary found

in the *PEI Register* for January 8, 1825.

DIED on Thursday the 6th instant, in the 87th year of his age, after a long confinement, which he bore with the firmness of a Christian, Mr. Benjamin Chappell, late Postmaster of this Island. In recording his death, we feel it our duty to give the public a brief sketch of this venerable man. Mr. C. was an Englishman by birth, and came to this Island with his family, in the year 1775, where he continued to reside until the period of his death. He saw the country in its rude and wilderness state, and was an attentive observer of all the vicissitudes it underwent, in its gradual progress to its present state of improvement; and we will venture to say, that no one took a more deep and lively interest in every thing that related to its welfare and happiness. He was a man of great piety, and actively devoted to the cause of religion, and may, with truth, be considered the nucleus that has given existence to the present Methodist establishment of this Island. He was personally known to, and affectionately beloved by John Wesley, who was in the habit of corresponding with Mr. C. for many years; and it afforded the deceased a source of much apparent delight, to detail to his friends a number of little interesting anecdotes that grew out of his intimacy with this great and good man. Mr. C. was brought up to the millwright business, and was well acquainted with machinery in all its extensive branches. He was a man of intelligence and strong mind, and with a perfect knowledge of his own profession, possessed a great deal of useful and well-digested information. If habits the most mild and unassuming; if a life of integrity and religion happily combined with the various moral virtues that dignify our nature, can endear a man to society and render him respectable, the memory of Benjamin Chappell will be long and affectionately cherished amongst us (1825, January 8, *PEI Register*, p. 3, c. 3.).

Chapter 2

Isaac Smith and the Greek Revival

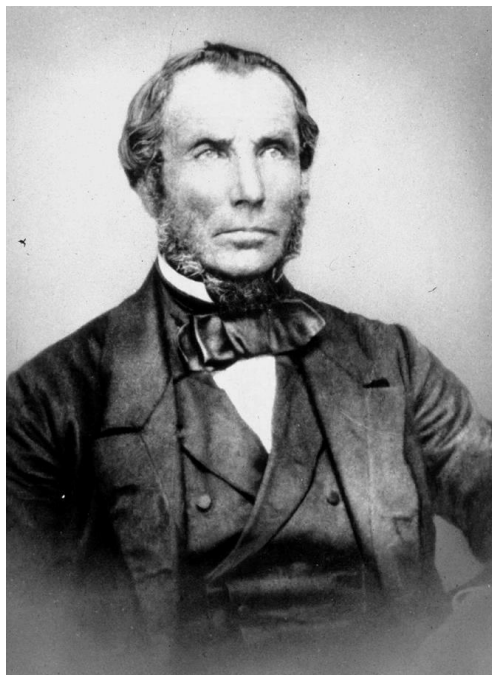

Detail of photo of Isaac Smith. Porter Collection.

The second phase of Methodist building in Charlottetown is dominated completely by Isaac Smith. He was a Yorkshire man born in the tiny village of Harome, about two miles away from the nearest market town of Helmsley, contained in the vast estate of Dunscomb Park owned by Charles Duncombe, a wealthy commoner whose fortune had been made in banking. Duncombe lived in a massive Palladian House built in 1713 that was surrounded by over 40,000 acres of land, the area of two lots in Prince Edward Island! The gardens surrounding the house and its outbuildings would have been both formal and natural and two great mediaeval ruins, Rivaulx Abbey and Helmsley Castle, were all part of the pleasure grounds. It is in this world that Isaac Smith spent his first twenty-four years before he

emigrated to Prince Edward Island in 1817.

During his years on the estate he, like his father, was likely part of the great workforce that kept all aspects of Dunscomb Park – buildings, gardens and ruins – in the best of shape. Undocumented sources tell us that Isaac's father was a carpenter and that the son was probably trained in that trade. We can only speculate about what skills in carpentry, masonry and draughtsmanship young Isaac might have brought with him and how these might have been augmented in his early years in Charlottetown.

It is as a carpenter that we first become aware of Isaac Smith in Charlottetown. There is no known documentation of what Smith did from the time of his arrival in 1817 until he is recorded as having completed John Plaw's round market house in Queen's Square in 1823, Plaw having died in 1820. Smith and Plaw probably knew each other in the three years before Plaw died and we will always wonder what, if any, influence the famous architect had on the much younger man. Smith's subsequent career in building indicates that he was a person of extraordinary talents, not only in the practical aspects of his profession, but also as a designer of good taste and restraint who kept up-to-date with the latest trends in international architectural design.



The former 1812 Helmsley Methodist Chapel. Guyler Archive, Oxford Brookes University Library.

Isaac Smith was a devout Methodist. There was no Methodist chapel in Harome until 1909 when the present church was built, but in 1812 a small Primitive Methodist chapel was built in Helmsley, serving both Methodists and Quakers. Perhaps this is the chapel memory he took with him to Prince Edward Island.

Shortly after his arrival in 1817 Isaac Smith joined the local Society of Methodists (Morrow 1985) where he worked as a class leader, lay preacher and eventually as a trustee. He soon met Benjamin Chappell and joined his circle. In time he would become the chief architect of Methodism, while also working for Anglicans and Roman Catholics. By 1833 the small chapel built on Richmond Street in 1816 was overcrowded and inadequate for the needs of an ever-expanding congregation. A new and larger chapel, designed by Smith, was begun in 1833, but owing perhaps to lack of leadership, the work went slowly.

Nineteen years ago the friends of Methodism laid the foundation of their first place of worship [1816 chapel on Richmond Street]. 'Small and feeble was their day.' Owing to causes to which we will not here refer, that place of worship was never finished. So dilapidated had it at length become, that to repair and finish it was deemed a waste of money and labor, and consequently a new edifice was projected. A spot of land [on the corner of Prince and Richmond Streets] was tendered at a reduced price by a friend in this town, a frame was provided and set up; but the fears of the society and congregation predominating over their hopes, it progressed towards completion but very slowly. Recent circumstances, however, justify us in the conclusion that this was not from any lack of good wishes and benevolent intention on the part of the inhabitants. Fortunately for the cause of Methodism in this town, in 1834, the British Conference appointed to the charge of this circuit our present highly respected minister who has deservedly gained the respect of all classes of this community, and who by his counsel and diligence, has aroused us from that supineness into which we had fallen. The determination to finish our chapel was soon formed, and to aid us in the undertaking, an appeal was made to the Christian benevolence of the public, and never was there an appeal more cheerfully responded to, than on that occasion. (1835, July 31, *The Royal Gazette*)

Smith was already a trustee at that time and would soon oversee the project.

On the 16th of November, 1833, Isaac Smith, Robert Longworth, John Bovyer, Christopher Cross, Henry Smith, John Trenaman, William Tanton, Thomas Dawson and Charles Welsh as trustees of the Wesleyan Methodist

Society in Charlottetown purchased a piece of land 80 by 168 feet on the corner of Prince and Richmond streets for the purpose of erecting a new Wesleyan Chapel. (Smith 1902)

...
 Having obtained this superior location the trustees erected an oblong wooden structure 42 by 55 feet with the gable end fronting on Prince street. The interior was plainly finished with flat ceiling, high backed pews and a gallery around three sides. The building would seat about 600 persons. (Smith 1902)

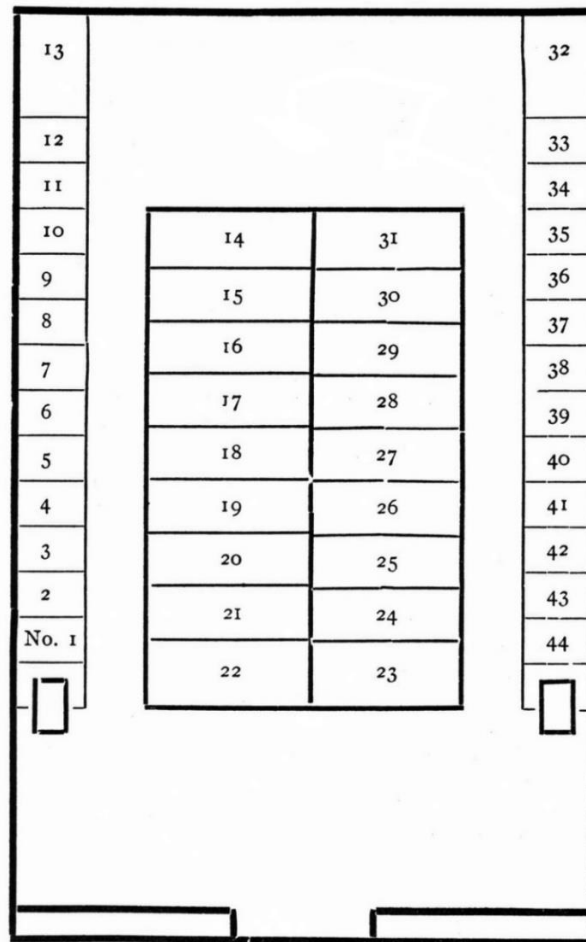

PLAN OF LOWER PART OF CHAPEL.

Plan of Smith's 1833 Wesleyan Chapel. Note: this is not an architectural drawing, but a diagram made up by the printer. PEI Magazine, v. 4, no. 12, February 1902, p. 435.

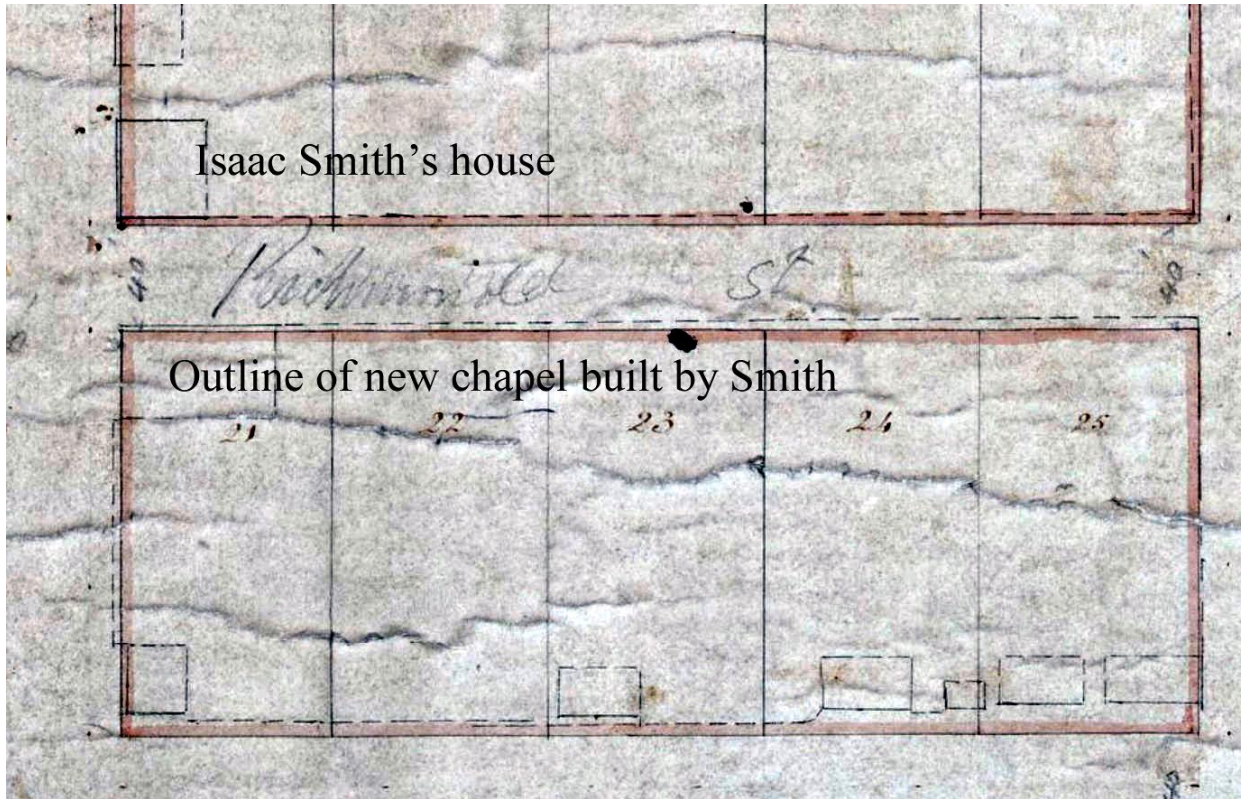

George Wright's 1833 manuscript map of Charlottetown showing encroachments in the city plan. We can plainly see the outline of the new chapel being built across the street from Isaac Smith's house. PARO.

The new Wesleyan Chapel was opened for divine service on Sunday the 9th of July 1835. The Rev J. P. Hetherington, the resident minister, preached in the morning. The service commenced at half past ten o'clock. The chapel was crowded to the doors, upwards of seven hundred persons being present. The text was from Luke XI, 2: "Hallowed be thy Name." The Rev. Wm. Wilson of Bedeque preached at half past three in the afternoon from Psalms XCIII V. "Holiness becometh thine house, O Lord, forever." At half past six in the evening the Rev. Richard Knight of Halifax preached a dedication sermon from 2nd Chronicles VI, from XVIII – XXI "But will God in very deed dwell with men on the earth? behold the heaven and heaven of heavens cannot contain thee how much less this house which I have built" etc. The whole services were solemnly affecting and highly interesting. The collections at the three services amounted to nearly twenty-three pounds. (\$74.00) (Smith 1902)

The chapel was very plain and austere and the elements of its 42-foot façade were arranged symmetrically, following a century of Georgian tradition of building classically-inspired chapels for Wesleyan congregations. The building was only

three bays wide with a central pedimented entrance. The gallery windows were all elliptical and the attic space was lit by a segmental window with a fanlight. It was a very conservative building, the kind Smith would have been familiar with in Yorkshire, except that in England stone would have been used, not wood. This temple-like structure must have dominated that area of the city, towering over the smaller houses from Water Street to Queen's Square, where Plaw's very small courthouse stood. It would be another year before the Anglicans would build their own tiny wooden church on the east side of the square.



The 1835 Wesleyan Chapel on the corner of Prince and Richmond Streets, designed by Isaac Smith in the Greek Revival style. On the corner across Richmond Street is the house where Smith lived. Next to it, and still standing at 100 Prince Street, is a dwelling built by the Smiths in 1827. Detail from a watercolour by Robert Harris, circa 1964-65. CAG.

We know little of the interior design and arrangement of this chapel in its various phases. It most likely would have been plastered and the door frames, window frames and baseboard simple and elegant in style, and quite probably identical to the trim that can be seen at Government House today, also built by Smith.

There was a gallery that went around three sides. From the schematic plan of the seating arrangements found in the chapel in its first phase of construction in 1835,

we see that the pulpit at that time was in the middle of the east wall. It would have been raised on a platform accessible by steps, perhaps similar in concept to that shown in this old engraving.

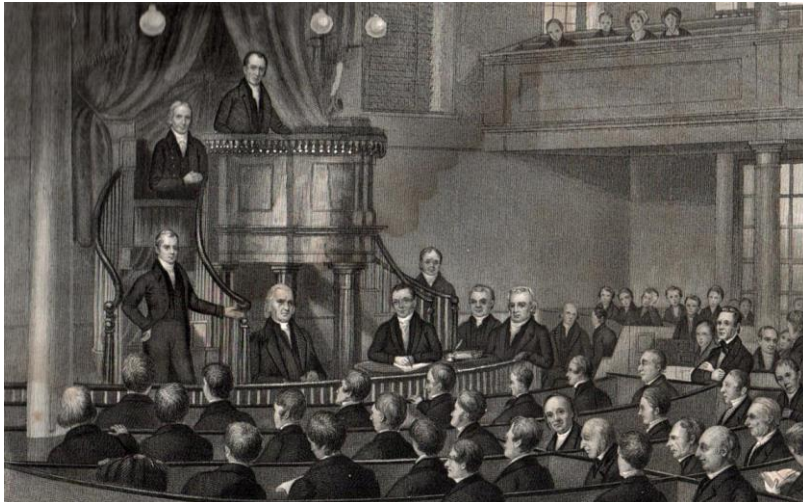

Engraving from Stevens, Rev. A. A.M., *Memorials of the Introduction of Methodism into the Eastern States*, 1848.

Money must have been scarce because it was only the next year they were able to finish paying for the building of the chapel, and even then, they had to borrow it. The loan had to include funds to build a home for the pastor, called the Mission House.

On the 13th of June, 1836, the trustees met and after agreeing to borrow fifty pounds on their joint note to pay Smith and Wright on account of balance due for building the chapel, they appointed Isaac Smith, Robert Longworth, John Boyer and John Trenaman a committee to enter into a contract with Christopher Cross to build a new Mission-house. They also purchased a half town lot adjoining the chapel property on Richmond Street, for forty pounds, on which to build the mission-house. This made the land 80 feet on Prince Street by 225 feet on Richmond Street. (Smith 1902)

This 1836-38 Mission House still survives today at 215-217 Richmond Street, where it was moved in 1875 when the congregation decided to build a new brick manse for the minister. The interior is still largely intact with a Chinese Chippendale transom in the entrance hall and extremely austere and elegant mantelpieces with full Tuscan Doric colonettes holding up the shelf in the principal rooms.



Detail of circa 1865 photo showing the 1838 residence for the minister still in place. Christopher Cross was the builder, probably following a plan devised by Isaac Smith. PARO.



1836-38 Mission House, originally built behind Smith's chapel, where it remained until 1875, when it was moved across to the north side of Richmond Street where it survives as numbers 215-217.



Transom in the Chinese Chippendale style over the front door at 215 Richmond Street.



Wooden mantelpiece by Isaac Smith with Tuscan Doric colonettes.

During the time Reverend Richard Knight was pastor, Methodism spread so quickly in Charlottetown,

... that in July 1837, — two years after the new chapel was opened — it was found necessary to enlarge the building by adding 30 feet to its length, making the chapel 85 feet long on Richmond Street. For this purpose, and to pay the balance due on the erection of the Mission House, the Trustees borrowed two hundred pounds, for which they gave their personal security. (Smith 1902)

In just eight years, yet another extension to the chapel would have to be made, at this time at right angles to the original already-enlarged structure. The new wing would bring the seating capacity up to 1000 worshippers.

In July, 1846, the Rev. William Webb succeeded Rev. J. B. Strong as Pastor of the Charlottetown Circuit. During Mr. Webb's pastorate it was found necessary to again enlarge the Chapel, and, at a meeting of the Trustees held 25th February, 1847, with Rev. Mr. Webb in the chair, the following resolution was unanimously passed: —

“Resolved that a public meeting of the pew-holders be held in the Chapel on Tuesday evening, the 2nd March, for the purpose of laying before the whole congregation the subject of the enlargement of the Chapel.”

A committee, consisting of Ralph Brecken, John T. Thomas, Charles Young,

George Beer, James Moore and Thomas Green, was appointed to solicit subscriptions (Smith 1903).



The 1835 Prince Street Methodist chapel after its enlargement in 1837 and further expansion at right angles in the middle of the south side of the first two phases of construction, in 1846, just eleven years after it was first built. Detail of 1863 photo, PARO.

The detail above is the only known almost-complete photo of the Smith Chapel, taken in 1863, while the roof beams of the new Gothic Revival brick chapel were being erected. Despite the blown-up detail it is possible to see a fair amount of architectural detail, especially in the corner boards and the exterior window frames. It is all the evidence we need to be sure that Smith built the chapel in the newly-fashionable Greek Revival style which had very wide corner boards topped by a modillion bracket and horizontal board sheathing with grooves to imitate the stone dressing technique called French Rustication which was being applied to all the wooden houses being built in and around Charlottetown at that time, mostly by Smith and his associates. Government House and the Central Academy were built using that stylish cladding and, in a few years, it would appear, in stone, on the first level of Province House.

The best illustration that survives of what Smith's chapel looked like in its final state is to be found in this ink drawing done by C. B. Chappell in November of 1902 and preserved by the Trinity United Church Archives. The drawing very

clearly shows Smith's chapel in its final state, which survived until 1864.

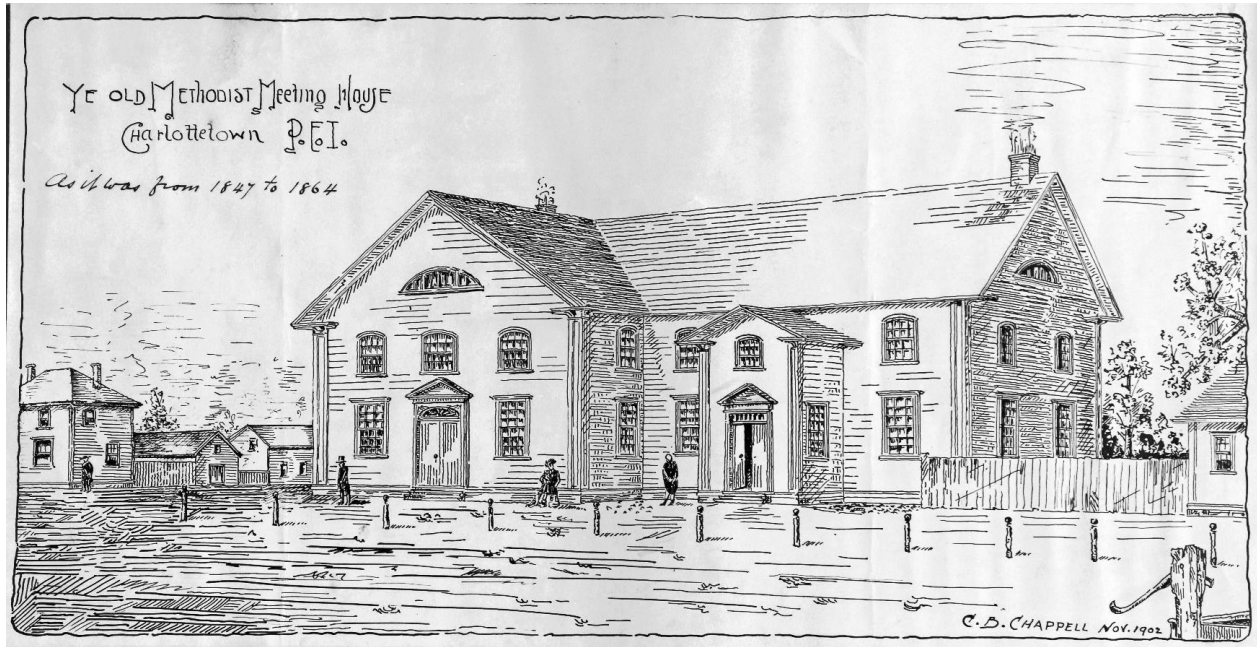

C.B. Chappell, First Methodist Chapel, Nov. 1902. Ink drawing. Trinity United Church Archives.

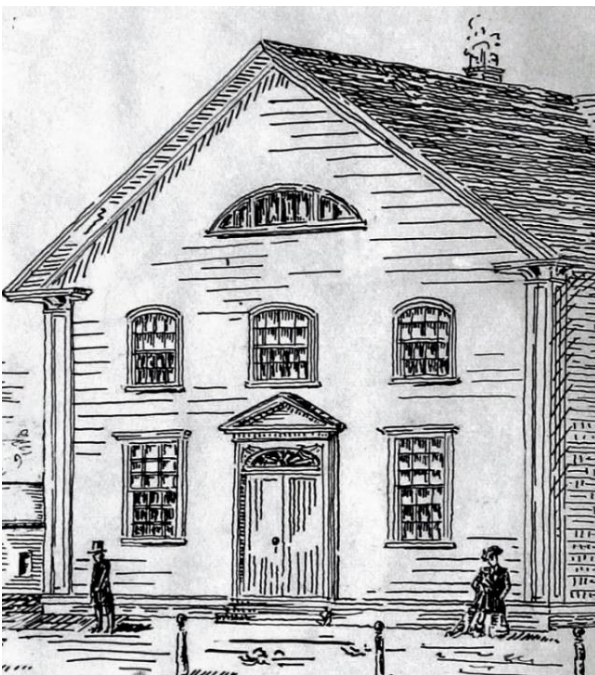

Detail from Chappell drawing showing the façade of the original 1835 church in the fashionable Greek Revival style popular until the 1850s.



Detail of the second entrance to the enlarged chapel, with a porch, constructed in 1846, in a style similar to the 1835 building, but with a transom rather than fanlight above the door.

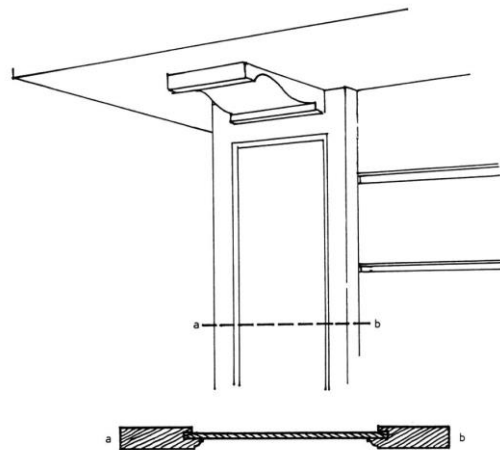

Drawing by David Webber showing the elements of Smith's Greek Revival style of the 1830s.

Isaac Smith interpreted the fashionable Greek Revival style of the 1830-40 period using this kind of corner board capped with a modillion under the eaves and cladding made of horizontal grooved planks made to resemble a stone treatment called French Rustication. It is possible that it is an adapted Plaw design found in his Courthouse.

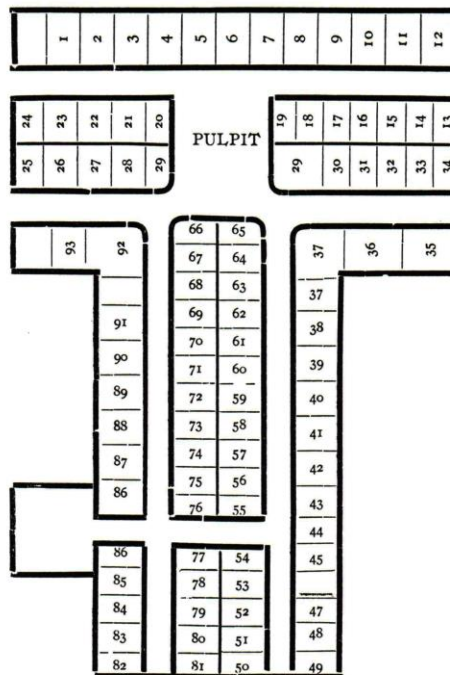

PLAN OF FIRST FLOOR OF CHAPEL, 1847—1864

We do not have an accurate plan of any of the stages in the construction and expansion of the chapel, but in Henry Smith's article in the *Island Magazine* (1903) there is a schematic diagram (above) of the disposition of the pews in the third and last phase, and that gives us some idea of the interior arrangement. The pulpit now appears to have been backed by the north gallery.

In this plan it appears that the original entrance to the 1836 structure, while still functional, opened onto the backs of pews that were flanked by two aisles. The pulpit was directly ahead and was aligned on a north/south axis, moved ahead and backing onto a new north balcony. There were now balconies on all four sides. It faced another block of pews flanked by aisles on either side. The new main entrance, complete with porch, was on the Prince Street side of the last extension and opened onto what appears to be a narrow aisle. Since this diagram was created by the printer using stock type and manually adjusted spacers, we cannot use it to estimate actual dimensions. It does tell us though that the new 1846 wing appears to have been centered at right angles on the long rectangle of the first 1835 building with its 1837 addition.

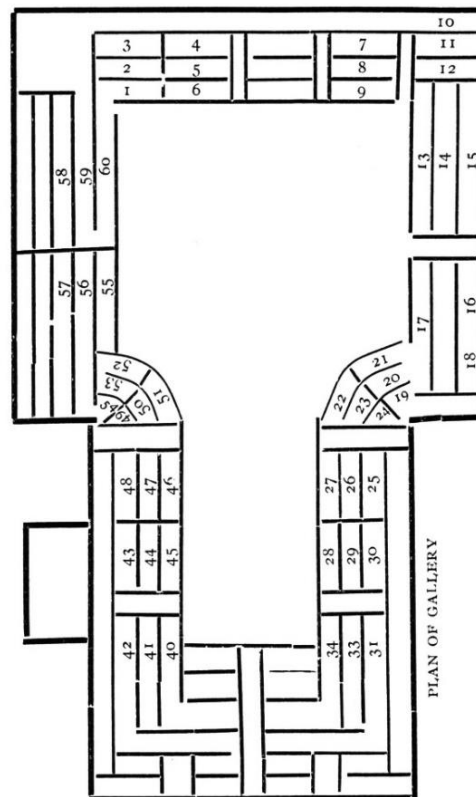

Henry Smith also provides a schematic plan (above) of the seating arrangements in

the gallery of the 1846 state of the chapel. (PEI Magazine, 1902)

Isaac Smith left Charlottetown for Nova Scotia on May 6, 1848, shortly after he had submitted his final accounts on April 5, 1848 for the building of Province House (1842-48). He went to Halifax to become the travelling agent for the Nova Scotia British and Foreign Society, a job that would take him all over the Maritimes. Smith did not lose touch with Prince Edward Island, visiting regularly, and probably doing business, until his wife Jane died in 1856 (Morrow).

It is significant that Smith continued as a Trustee of the Methodist chapel until 1862, fourteen years after he had left the city. He would have been aware of the plans to build a new brick church in what we now call the Nonconformist Gothic Revival style and that a younger man, Thomas Alley, at the beginning of his career, would be the architect. One cannot help but wonder how Smith felt at this decision to replace the old with the new.

The Rev. John Brewster was the last minister who closed his pastorate in the old chapel. He was appointed to the Circuit in 1862. In September of that year the trustees purchased the land on the corner of Prince and Sidney streets adjoining the chapel property, with a view to the erection of a new place of worship. They also appointed a committee to procure plans for a new building. Mr Isaac Smith, who had removed to Nova Scotia, resigned his position as Trustee, and Mr. William Heard was appointed to fill the vacancy on the Board. Mr. William Tanton also resigned, and Mr. Mark Butcher was appointed in his place (Smith 1903).

The period 1830-48 had been the glory years of the Greek Revival in Charlottetown and on the Island. Starting in 1830 with repairs to the Plaw Courthouse, during the next eighteen years Isaac Smith would be the prime mover behind more than a dozen major building projects that we know about: The Central Academy (1832); the Georgetown Courthouse (1832); Government House (1832-34); the Saint Eleanor's Courthouse (1833); the Wesleyan Chapel (1833); Saint Paul's – first attempt (1833); work at Saint Augustine's, Rustico (1834-45); Saint Paul's – second stage (1836); the Wesleyan Chapel – second stage (1836); school in Georgetown (1840); Province House (1842-48); Pownal Street Wharf (1842); the Infant School at Saint Paul's (1843); plan for Saint Dunstan's College (1844); extension to Saint Paul's (1845); final extension to the Wesleyan Chapel (1845); the Lunatic Asylum (1845); and the Point Prim Lighthouse (1845). What a catalogue of the most varied achievements!



The 1845 wing of Smith's Greek Revival chapel was moved to 121-23 Prince Street to become a tenement house. Its elegant Greek Revival proportions can still be seen.

It seems significant that Isaac Smith broke his connections with the Wesleyan congregation in Charlottetown just a year before they began construction of a new, much enlarged, brick church in the newly-fashionable Nonconformist Gothic Revival style, designed and articulated by fellow members of his old congregation, Thomas Alley and Mark Butcher. By 1865 all traces of the Greek Revival style, so consistently promoted by Smith for nearly thirty years would disappear, except for the 1845 wing, which was moved to 121-23 Prince Street to become a tenement house. That is all that remains of Smith's Prince Street chapel.

There is a sadness in all this. We do not know if Isaac Smith ever saw the fashionable new brick chapel, completely different in every way from his vision of the Greek Revival, embodying the classicism of his first and lasting impressions of the ideal 18th Century Wesleyan chapel.

Chapter 3

Methodism and the Gothic Revival

At this point in the story of Methodist architecture in Charlottetown, before we begin our discussion of the new brick chapel, a digression is necessary to explore the nature of the Gothic Revival style that was sweeping across Britain and America. Even though the Minister, Rev. John Brewster, at the laying of the corner stone on Monday, May 25, 1863, was at pains to say that the chapel was “simple, plain, and exceedingly primitive” this was very far from the reality that would soon rise above the southeast corner of the city! Brewster was obviously playing down what must have been very intense, perhaps tense, discussions on the appearance of the new brick church by the trustees and members of the congregation. It was at the cutting edge of the new Nonconformist Gothic Revival style that had been adopted by progressive Methodist congregations in Britain and North America for the past generation.

The Gothic Revival – An Explanation

At the beginning of this manuscript, the state of the Anglican Church at the beginning of the Eighteenth Century was discussed in relation to the emergence of John Wesley and the establishment of Methodism. By the early 19th Century, new trends appeared in the Anglican Church that recommended that the Church be more liberal in its views and more accepting of congregations that were not mainstream. Others, influenced by the evangelism of groups like the Methodists, turned to a more Bible-oriented approach in worship, while still maintaining communion privileges with the mother church. A third group, found especially in university environments, began to take a serious interest in Christian practice before the Reformation – in essence, Roman Catholicism, its architecture and liturgy.

The movement gained momentum, especially at Oxford, where it got the name “Tractarianism” after a series of essays called “Tracts for the Times” were published between 1833-41. Prominent among this group of eight or so writers were John Henry Newman and Edward Bouverie Pusey. Soon churchmen spoke despairingly of “Newmanites” and “Puseyites.” The whole movement was also called the Oxford Movement. John Henry Newman went so far as to claim that the Thirty-Nine Articles of the Established Church did not in the least conflict with the doctrines of the Council of Trent, which was the Catholic Church’s response to the Protestant Reformation. Newman, and another member of the group, Henry Edward Manning, eventually became converts to the Catholic Church, where they enjoyed much popularity and exercised considerable influence.

The Oxford Movement grew in extent and influence and soon, in some sympathetic congregations, the trappings of worship began to revert to the traditional vestments of the Catholic church and large parts of the Tridentine liturgy were also revived. The next step, predictably, was an expressed desire to worship in spaces appropriate to these restored practices, and that, of course, meant Gothic churches and chapels inspired by the pre-Reformation Middle Ages. In that milieu, a powerful interest in Gothic architecture was born which led to the establishment of the true Gothic Revival among Anglicans, and later, among Nonconformist congregations.

The Gothic style had never ceased to be used in Britain because that country had not experienced, in any extensive way, the fashion for Renaissance architecture that swept through Europe in the 16th Century. Gothic still appeared into the beginning of the 17th Century. Only slowly, in the Baroque Age, did classicism appear on a large scale in grand palatial structures. This classicism evolved, in the 18th Century, into the neo-Palladianism which characterised the great country houses being built by aristocrats and a new moneyed class, the product of the Industrial Revolution.

During the 18th Century, a spiritually unhealthy practice of turning to the Middle Ages for inspiration in new sensations of horror and depravity began to appear in literature, such as *The Castle of Otranto*, a 1764 novel by Horace Walpole. This was hugely popular and a new movement in taste manifested itself in more books and secret societies for the wealthy and privileged who, dressed in monkish garb, carried on outrageously and sacrilegiously in grottoes and pseudo-Gothic structures. The architecture of this Romantic Gothic style was not one of stone using traditional techniques of mediaeval masons, but mostly ornament and pattern applied with lathe and plaster.

These practices were looked upon with scorn by the Tractarians who now turned their attention to the study of real churches and chapels that had survived destruction under Henry VIII when he broke away from the Roman church. Books began to be published, illustrated with lavish engravings, and soon architects began to construct new buildings in as pure a Gothic style as possible.

On 16 October 1834 the mediaeval British Houses of Parliament were engulfed in a huge fire that could be seen for miles. When the moment came to rebuild these structures, vital to the operation of government, a choice was made to return to medievalism and not turn to the classical styles that dominated all major architecture at that time. A commission was brought together to set up a competition to rebuild the missing structures either in the Gothic or Elizabethan style. The competition was won by the architect Sir Charles Barry and construction on the great project began in August of 1840. Barry was a fine architect but did not have the knowledge necessary to articulate correctly the many details that comprise true Gothic decoration, so he hired a lesser-known, but highly-informed architect, Augustus Welby Pugin, to be his design assistant.



Sir Charles Barry, from an old engraving.

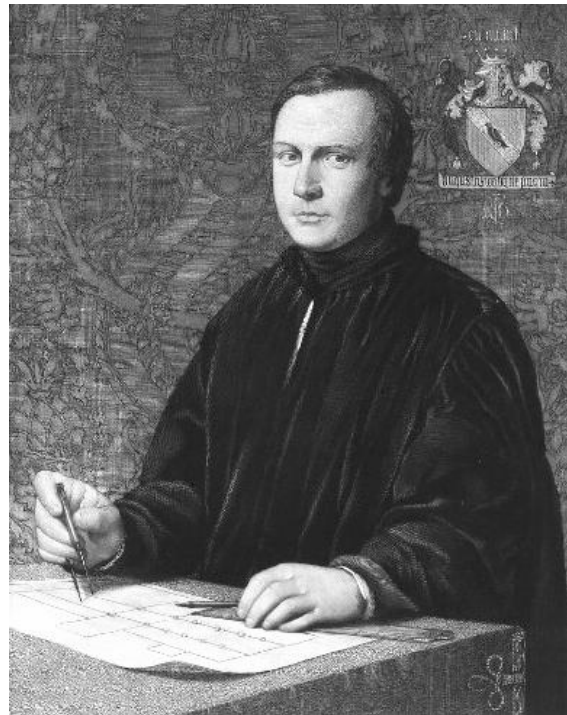

Augustus Welby Northmore Pugin, lithograph by James Henry Lynch, after John Rogers Herbert, 1853

Augustus Welby Northmore Pugin, (1812–1852) was an English architect, designer, artist, and architectural critic who is principally remembered for his work

In his role as architectural critic, Pugin wrote four books that were to have an astonishing effect on the future progress of architecture, especially ecclesiastical, in Britain, North America and even Australia. His first book, with the long-winded title, *Contrasts: Or, A Parallel Between the Noble Edifices of the Fourteenth and Fifteenth Centuries and Similar Buildings of the Present Day. Shewing the Present Decay of Taste. Accompanied by Appropriate Text* and was published in 1836. In it Pugin argued for the use of “pointed” or Gothic architecture for all manner of religious and civic architectural projects, by contrasting beautifully engraved plates of the two complexes he was discussing – a church or government-funded homes for the poor – showing one in the current soulless stripped classical form that was popular and the other as it would have appeared in the Middle Ages. The book was immensely popular and was avidly read by both Catholic and Protestant churchmen and philanthropists.

His other book, equating Christian with Gothic and stressing the need for the stonework of ancient masonry, was called *The True Principles of Pointed or Christian Architecture* and published in 1841. In 1843 he published two more books, expanding on what he had already written, *An Apology for the Revival of Christian Architecture in England* and *The Present State of Ecclesiastical Architecture in England*. These books were eagerly taken up by the religious and architectural community and were responsible for a complete change in the face of 19th Century architecture in Great Britain and North America.

Throughout the 18th and early 19th Centuries the architecture of Methodism and other Nonconformist sects was, for the most part, based on classical models with an emphasis on the “temple” look. But the Nonconformists, especially the Methodists, were very active in the various roles they played in civil society, especially that of education. They strove to be recognised as a sect that was in touch, not only with Scripture, but with the problems of the modern world they lived in. Adopting the fashionable Gothic style and “fitting in” was soon seen as the best way to get ahead. The Methodists, however, were not prepared to adopt the old Catholic church designs for their chapels. They were perceived as tainted by the Church of Rome and all it represented in drama and ceremony and the setting aside the primacy of Holy Scripture. Various solutions to this problem were quickly found in the architecture of the Protestant Tudors who still built in the Gothic, not the fashionable continental Renaissance style. The most obvious model to emulate was King’s College Chapel at Cambridge which was Gothic, Protestant and a chapel, not a church. This style was echoed in civil architecture as well, such as the little battlemented turrets flanking the West Front at Hampton Court.



King's College Chapel, Cambridge 1441-1515. Private Collection.



Cardinal Wolsey - Hampton Court, West Front, 1515. Detail from an old postcard.

It was from buildings such as these, especially the chapel at Kings, with its simple huge gable end pierced by a vast window with a large door underneath, and its two slender turrets flanking the whole, that would eventually inspire Nonconformist architecture in the United Kingdom. These small turrets, divided into stories by belt courses of contrasting stone, as can be seen at Hampton Court, would in time find their way to North America and, just before Confederation, in Charlottetown.



Barry, Sir Charles, Upper Brook Street Unitarian Chapel, Manchester. 1837-39. Photo Wikipedia.

A major architect had to be found who would produce a prototype Nonconformist chapel, and no less than Sir Charles Barry, the architect for the rebuilding of the Parliament Buildings would do. Barry went to Manchester where he designed, in the Gothic style, but with the Protestant outline of Kings College, a sandstone chapel suited for an urban Unitarian population. It was to be seven bays deep with a lancet window in each bay. The façade of the chapel would have an enormous Gothic window filled with elegant tracery, and below it a massive Gothic doorway, carved through the great thickness of the wall, just like in the mediaeval cathedrals.

Flanking the façade was an arrangement of buttresses topped by a pinnacle. The chapel had galleries on three sides. The attached Sunday School was built in a similar style. The chapel has had a coloured history, starting off as Unitarian, then Baptist, then Jehovah's Witness, an Islamic school and mosque and now a residence for university students. The greater part of the chapel had collapsed and after being given heritage designation it has been completely restored on the exterior.

The Manchester Upper Brook Street Unitarian Chapel has the distinction of being the first Nonconformist building in the Gothic style. Its progeny would soon be found all over the world.

When the time came to build a new Methodist Chapel in Charlottetown, there must have been a considerable degree of general anxiety connected with this project, most particularly as to what style should be adopted. For some years both Catholic and Protestant sects had been aware of the growing popularity of the Gothic style.

A considerable number of churches were built in the 1820-40 period that demonstrated this new interest. As early as 1823 the Parish of Miscouche built a small three-bay church with Gothic windows, which was followed in Mont Carmel in 1827 with another much larger, five-bay church. In 1824-26 the elegant Saint John's Presbyterian church was built in Belfast by Robert Jones. The large second church built in Tignish in 1826 kept the neoclassical style. Isaac Smith's 1833-35 Methodist chapel in Charlottetown was neoclassical, but with the new fashionable Greek Revival details in the trim. The very large 1834 church at Egmont Bay was also classical although it had a large three-tiered tower with crenellations and a needle spire. The 1836 First Baptist chapel at Crossroads was severely classical – perhaps the best of its kind – only two bays deep and with no tower or porch, while Smith's Saint Paul's in Charlottetown, built the same year, had three Gothic bays, a triple-tiered tower and a needle spire. The Methodist chapel at Covehead West built in 1837 has two magnificent Gothic bays but a pedimented classical entrance. The 1837 Catholic church at Georgetown was in the Gothic style with a three-level tower and spire flanked with four tall pinnacles while the 1839 church at Grand River remained severely classical although it also had a three-level tower with tall pinnacles. The 1838 Anglican church at Saint Eleanor's had three bays, filled with very large Gothic windows, as did Saint Augustine's church at Rustico, also begun in 1838. Both had triple tiered towers. The church of Saint James at Port Hill, built in 1841-43 had two Gothic bays. The 1842 Holy Trinity Anglican church in Georgetown was also Gothic with a three-level tower with crenellations and pinnacles. So too was the new two-bay Anglican church at Cherry Valley.

In 1843 the new wooden Saint Dunstan's in Charlottetown was built in an ambitious Gothic style with six bays and an elaborate tower with buttresses, a clock, pinnacles and a needle spire. In 1848-49, the Clifton Methodist (now United) church was built in an old-fashioned severely classical two bay style. Around 1850 the 1826 Gothic Kirk of Saint James was renovated in a more elaborate Gothic style with two large bays and a tower with tall pinnacles and elegant rail cresting. There would be few churches built in the 1850s, the 1855 DeSable Church of Scotland in the Gothic style, with its peculiar lateral interior arrangement to suit the needs of a local liturgy, being the most important.

We note emphatically that while most of the churches or chapels built in the 1820-50 period are today labelled "Gothic," that is a courtesy that refers to applied decorative detail only, in the windows and towers, with their varied elements. All these buildings, even the trend-setting Saint Dunstan's of 1843 had, as the core structure, a classical style with a low roof pitch more appropriate to temples than to anything from the Gothic period, with its very high roof pitch.

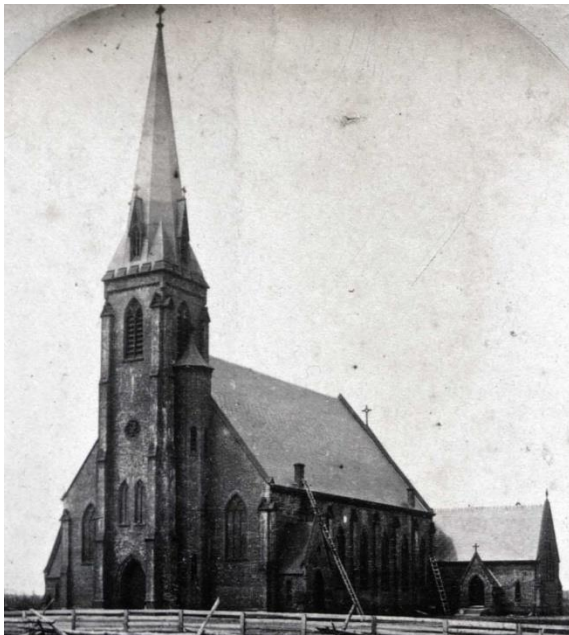

The church of SS Simon and Jude, Tignish, built out of local brick after a design by Patrick Keely in 1860. Elements found in this building – the turrets that flank the entrance, and the great stained-glass window in the sanctuary – would later be combined in the façade of the First Methodist Chapel in Charlottetown. Photos by Henry Cundall, 1860. PARO.

It would not be until 1860 that the first true Gothic Revival church was built on the Island at Tignish. Peter McIntyre, the parish priest, was an energetic and ambitious man who was in touch with the latest architectural trends, and he hired Patrick

Keely, a very prolific Irish New York architect who was a follower of Augustus Welby Pugin, to provide a plan. It is not surprising that the Tignish church resembles an illustration from one of Pugin's books. Saint Simon and Saint Jude's church was photographed in 1860 by the amateur photographer, Henry Cundall, who was doing extensive surveying work in the area. It is worth including his photographs here as they resonate in many ways with the new brick chapel the Methodists would build several years later.

The Methodist congregation in Charlottetown was very energetic and progressive and, when the time came to build their new chapel, would no doubt have been aware, from Cundall's photos at least, of the impressive potential of brick pierced by a great window and turrets and buttresses enclosing the bays.

THE JUSTIFICATION OF THE NONCONFORMIST GOTHIC REVIVAL STYLE

Since the appearance of Barry's Upper Brooke Street Unitarian chapel in Manchester in 1837-39, with its Tudor-derived façade, there had been much agitation in Methodist circles as to whether it was appropriate to leave behind the classically-inspired temples of the founder of Methodism, John Wesley, and accept the very progressive new stylish trend of the Gothic Revival based on true Mediaeval models. In 1850, just eleven years after the Manchester chapel was built, a most significant book was published by an author who was both a Wesleyan Methodist minister and an architect. His name was Rev F. J. Jobson, and his book had the resounding title of *Chapel and School Architecture as appropriate to the Buildings of Nonconformists, particularly to Those of the Wesleyan Methodists: with Practical Directions for the Erection of Chapels and School-Houses*.

The first two paragraphs of Chapter 4 present the essence of the argument for turning to the mediaeval Gothic style for inspiration:

WE have seen that Gothic Architecture is, in its origin and associations, Christian Architecture; and that, in its several varieties, it appeared, from early times to a late period, as the outward memorial of Christian worship. But the objection has arisen, that it was employed, chiefly, by a church that paid more regard to external forms and impressive ceremonies than to spiritual religion; and the question still remains, how Gothic Architecture can be appropriately employed by Wesleyan Methodists.

It may be averred that our Reforming forefathers, whose principles we hold, evinced a disposition to desert Gothic Architecture, and leave it to the Romish church. They did; and their immediate successors, the Puritans, in their zeal, broke down the “carved work” of English churches “with axes and hammers;” and, refusing to appear in connection with what had been diverted to superstitious and idolatrous purposes, they rejected the Gothic style of church-building, and erected “Meeting-Houses,” as irregular and as plain, in design and character, as the stables they built for horses, or the barns they raised for corn. And they were, in a great measure, driven to this course by the circumstances in which they were placed. They felt themselves to be so hemmed round with monuments of that which they abhorred, that there seemed no way of escaping from its influence but to clear the ground, and begin anew. But now that time has been given for calm reflection, and opportunity for avoiding extremes, Truth in Architecture is appearing; and the modern successors of the Puritans work not a little Gothic into their houses of worship, and thus give increasing practical proof that they perceive Truth in Architecture is not necessarily connected with Error in Religion (pp 39-40).

He goes on to show a significant interest in the organ and its placement in the church as an appropriate source of traditional musical accompaniment to worship instead of instruments used in popular entertainment:

And, already, the organ-loft has re-appeared, even in Nonconforming chapels. That grand and solemn instrument has banished therefrom the reedy, squeaking pipes and string-breaking fiddles, which too often broke the harmony of religious worship; and it begins to be admitted that Christians ought to have their hymning melody as harmoniously attuned in the House of God, as when they gather in choral groups for social enjoyment, in their own homes (pp 41-42).

Jobson is also, as an architect, deeply concerned about the way the old classically-inspired chapels are perceived:

I could refer to large Chapels in commercial and manufacturing towns which are more like warehouses or factories than Houses of God; and where, if in any case, a tall chimney were added on one side, the building would immediately appear ready for use as a cotton-mill or a wool-factory (p 44).

He is careful not to condemn the taste of his Wesleyan predecessors in their choice of building style:

Much less would I have it supposed that I write in condemnation of our venerable fathers in Methodism, who erected mis-shapen and unsightly buildings in which to worship God. They did the work of their day; and they did it earnestly and devotedly. They were mostly unpolished, but fervent and hard-working men, suited to the great and laborious foundation-work they had to perform (p 45-46).

He is also scrupulous in describing why the early Methodists built as they did:

Indeed, the first Methodists built their chapels rather for refuges of mere private communion, and for preaching-houses, than for places of public worship that should contain within themselves all the requisites of the House of God. They went to the parish-churches for prayers and sacraments; and purposed reviving and purifying and improving the Church of England, rather than to become a separate church. And it was not until they were driven away from the Lord's table in the Established Church, and their faithful teachers were turned into the fields and the streets, that they began to entertain the idea of becoming separatists (p 46).

On page 49 he is very specific about why and *how* the Gothic Revival Style should be adopted, in the purest, most basic manner possible:

Nor would I, while advocating the adoption of Gothic Architecture for ecclesiastical purposes, be understood to be pleading for unnecessary forms and ornaments,—or, that we, as a people, should adopt *all* the arrangements and enrichments of the Gothic churches in this country. They were built for the exhibition of ceremonies which we, as Protestant Christians, do not approve. We do not confine the church to the clergy, and therefore need not make so much of the chancel, nor screen it off from the gaze of the multitude by carved work. We do not “offer up the daily sacrifice of the mass,” and therefore need not make all things give way to the “high altar,”—nor place the pulpit on one side to show the altar. We make prominent the preaching of Christ's gospel, and therefore the pulpit should be in the most convenient place. If we use no bells, we need no towers; and as we employ no processions of ecclesiastics to impress the senses and to inspire awe and reverence, we need not have “long-drawn aisles.”

Jobson reminds his readers that there is a definite financial reason for changing to the revival of the old style and this is supported by extensive research done through consultations with professional architects:

The Model Plan Committee, appointed by the last Bristol Conference, applied to six of the most able architects, residing in different parts of the kingdom, for designs, specifications, and estimates, in their quantities and prices, of a chapel to accommodate seven hundred and fifty persons, in Gothic, Grecian, or Roman styles: each architect to supply two designs — one in Gothic, and the other in Grecian or Roman — with their estimates. The result was, that in every case, the estimated cost of the erection of the Gothic design was less than the estimated cost of the others; and, in some instances, considerably less (page 52).

He goes on to say, tongue in cheek, that he is not criticizing the building practices adopted by some of his fellow Methodists:

But I forbear, for while I write freely, I must not even seem to condemn good and generous men, who, in their great zeal for God, committed, unintentionally, some improprieties (p 53).

He concludes Chapter 4 with a clarion call that, for all the reasons he stated, the Gothic style will triumph:

There is Truth in all things that are good; and force it down for a time as men may, and hold it under water by prejudice, as long as they can, yet, eventually, it will rise and be uppermost. Things will have their right place in the world, however disordered for a time; and so will Gothic Architecture (p 56).

Jobson calls his Chapter V “The particular wants of Methodism in chapel building” and devotes it to a discussion of several points made by “The Model Plan Committee ... composed chiefly of Ministers and Lay-Gentlemen in the neighbourhood of Manchester.” We believe it is important to present, in their briefest form, these conclusions as they are the very essence of the Methodist adoption of the Gothic Revival style:

WESLEYAN METHODISM has particular wants to be provided for in the arrangements of its public buildings. It is not the ordinary oblong Chapel,

however correct in its proportions, and consistent in its architecture, that will supply all it requires. It has its social means of grace; its religious education of the young; and its benevolent institutions for the relief of the sick and the poor, which must be considered, as well as the exercises of public worship, if the Chapel premises shall provide what is requisite to the efficient working of the Wesleyan system of Christian means and agencies (p 57).

The planning was very thorough on what should constitute not only the chapel itself, but all ancillary spaces and buildings connected with liturgy and education. The recommendations from this Committee total eleven. Here is the first:

1. It appeared to the Committee that, in preparing to erect Wesleyan chapels, sufficient consideration had not generally, been given to the want of Class-Rooms and Vestries. These are indispensable to the working of Methodism, in the present day (p. 58).

Experience had taught the Wesleyan Methodists that they could not often predict the extraordinary expansions of congregations, so planning architecture that permitted aesthetic expansion became of great importance:

2. Another consideration which engaged the attention of the Committee, was *the arrangement of the buildings in such a manner as most easily to admit of enlargement when required* (p. 59).

There is always a strong concern that the children be accustomed as early as possible to perceive being part of the congregation a component of their daily lives. There must be suitable seating in the chapel for the children when not in their classes:

3. Another and a very important object to be secured in Methodist chapels, and which was carefully and anxiously considered by the Committee, was *the furnishing of seat-room for the children of Sabbath and Week-day Schools*. This was not required in the earlier days of Methodism, but it must be amply supplied now, if Wesleyans are to maintain their consistency, and keep their position among the Christian churches of the land. The Methodist education of the young is avowedly *religious*; therefore, all the children under training in Methodist schools ought to be habituated to regular attendance on Public worship (p. 60).

Providing suitable seating for the poor – often a distasteful task to the more

successful classes in the congregation – was noted as essential. They are described as the base of the Christian pyramid and Scripture is quoted to justify provision of seating for them:

4. Another most important subject, which engaged the serious deliberations of the Committee, was *seat-accommodation for the Adult Poor*. The attendance of this part of the community is essential to the prosperity of Methodism, as to every other section of the Christian church. In addition to their being, by their very numbers, the broad and massive base of the pyramid of human society, — the granite foundations on which the sandstone, the chalk, and the tertiary formations rest in safety, — they are set forth in the language of Scripture, and by the teaching and example of Christ, as the peculiar charge of the Church, and its peculiar hope. “The Poor ye have always with you,” said the Redeemer. “Hath not God chosen the poor of this world, rich in faith, and heirs of the kingdom, which he hath promised to them that love Him?” said the apostle Paul. The church in prosperity has, at all times, had its most numerous members from the ranks of the Poor. (p. 62).

There then follows a long digressive 5th section on the necessity of avoiding going into debt and constructing buildings as economically as possible – neither too small; neither too large – but suitable for any given congregation for its present and future needs. There is considerable discussion of the benefits, but mostly negative effects of balconies as impediments to communication. Congregations are warned against ostentation and inessential decoration, implying that the very nature of the Gothic style itself provides, in its functional nature, all the decoration necessary.

The last six recommendations all have to do with the practical arrangement of space in the chapel, and all refer to specific aspects of planning:

6. *There should be no aisle down the middle of the chapel*, but seats: it being much better for the preacher to look directly upon his hearers, than upon an open space.

7. *There should be no gallery behind the pulpit*; lest the Minister should be annoyed by the shuffling of tune-books; or the worshippers should be disturbed in their devotions by the movements in the orchestra.

8. *The pulpit should be as low as the rake of the gallerias and the seats at the extremities of the chapel will allow*; and the pulpit, with the reading-

desk, should be *behind*, and not before, the Communion-table.

9. *The height of the pulpit should, from its own floor, be of the height convenient for a Minister of middling stature, so that it may be free from the very great annoyance often found in them, of foot-basses or stools.*

10. *The seats should be so far separate in their partitions, as to allow worshippers adequate room for kneeling in each pew.*

11. *The free seats should have backs to them, that the poor may have requisite support for their weary bodies; and should be of the same height and general construction as the pews which are let (pp. 77-78).*

To conclude this discussion of why the Nonconformist version of the Gothic Revival was enthusiastically promoted after Jobson's 1850 publication, we observe that the classical styles were quickly being abandoned for all the reasons discussed in this chapter. Jobson was eager to demonstrate this with suitable illustrations and he used them generously to make his point, again and again.

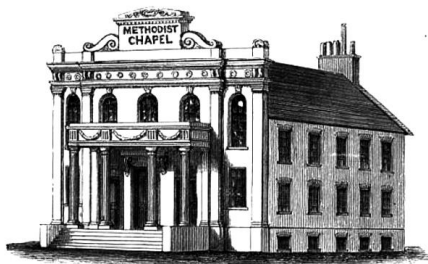

Classical Style.

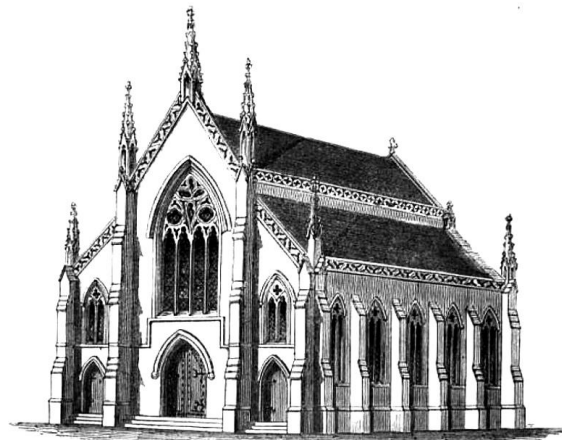

Gothic Style.

Jobson went to great pains to demonstrate how crass and vulgar the original 18th Century classical style had evolved over the years, when it could equally have been a bank, a theatre or any number of secular buildings. The Gothic church, however, based on the Protestant episode of Mediaeval Gothic building, could not be mistaken for anything but a place of worship. Engraving from Jobson, 1850, plate facing page 45.

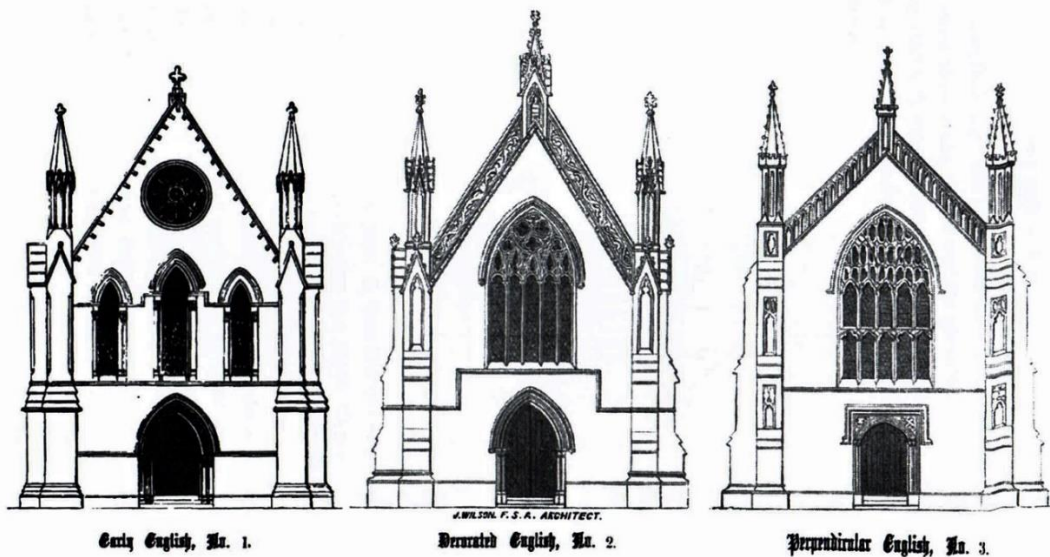

Jobson encouraged loyalty to the traditional English Gothic styles, and in this plate presented the acceptable limits of details taken from several centuries of English architecture as applied to the old preaching hall adapted to Nonconformist Gothic Revival. It became ubiquitous. Engraving from Jobson, 1850, plate facing page 27.

In Eastern North America, the Barry Manchester model from the 1830s gained prominence and, with variations of Tudor details in the façade, new chapels in the Gothic Revival style sprang up everywhere in the 1840s and '50s.



Henry Bowyer Lane – Church of the Holy Trinity (Anglican), Toronto, 1847.



Patrick Keely – Church of Most Holy Redeemer, Boston, 1854-57.



Charles Alexander – Chestnut Street Methodist Chapel, Portland, Maine 1856. Today it is a posh restaurant.



Chestnut Street chapel with its original spires. Postcard, circa 1910.

With such Eastern North American examples of the new ideal Wesleyan Methodist styles accessible through correspondence with other congregations or observed during the frequent and extensive travels of Methodist ministers at this time, it is no wonder that when the time came to build a new Methodist chapel in Charlottetown, inspiration and models were everywhere to be imitated.

Chapter 4

Thomas Alley, Mark Butcher and the Gothic Revival in Charlottetown



Photograph of the new Wesleyan Chapel immediately after it was built in 1864. It represents Thomas Alley's adaptation of a Nonconformist Gothic Revival design that had been popular for over a generation. PARO.

The design and construction of the new First Methodist Church in Charlottetown was the work of two members of the congregation. Thomas Alley was the architect

and Mark Butcher provided plans and specifications and supervised the joiners, painters and upholsterers for all the interior work (Rogers 1983, p. 203).



Thomas Alley (1820-1900)
PARO.

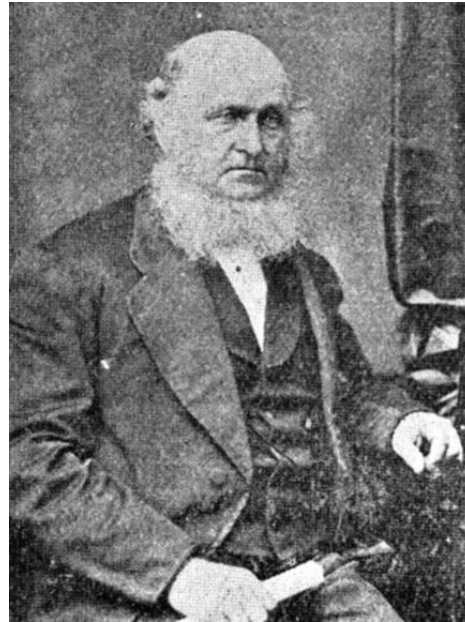

Mark Butcher (1814-83). Photo: R.
Porter Collection.

Thomas Alley was born on the Island on 12 August 1820. He first appears as a carpenter and little else is known about his early life. Presumably he was apprenticed to one of the major builders, but we do not know who that might have been. Since the most visible builder during the time of his apprenticeship was Isaac Smith, it is possible that is where he received some training. There appears to be no evidence of his having produced any building of consequence before he won the contract to design the new Methodist Chapel in 1863 when he was already 43 years old. We do not know if he received specialised training in architecture out of the province, nor are we sure what inspired the plan for the exterior of the church – a design that was favoured by Nonconformist congregations across the Eastern Seaboard and in Ontario.

There were two churches he might have been familiar with within travelling distance – in Bangor and Boston (see Chapter 3). The basic design of their facades, and that of the Charlottetown chapel, had several major elements in common: a tall high-pitched roof with the wall dominated by a huge window of Gothic tracery, below which was a massive doorway flanked by subsidiary doors. This central mass was flanked by tall octagonal turrets topped either with small spires or battlemented tops. In its time, Trinity United has had both. The building was

approached by a wide and tall set of steps to take into account the height of the basement with its generous windows.

Thomas Alley seems not to have been much interested in the Gothic Revival. His only other building with any personal connection to Gothic detail was the not very successful Prince Street Church of 1877. For the rest of his career he would devote himself to the fashionable Italianate style with round-headed windows and rusticated corners, producing such fine buildings as The Union Bank on Great George Street (1872-73), the Provincial Law Courts on Queen's Square (1874-76), a splendid house for himself at 62 Prince Street (1874-76) and the West Kent Street Public School in 1877. In 1879 he worked on the new Baptist Church on Prince Street, but the Gothic Revival design was based on a plan he obtained from an architectural firm in Montreal (DCB).

Mark Butcher (1814-83), was born in Suffolk, England, and moved to Prince Edward Island in 1829. By 1835 he had set up a workshop in the city and there became the foremost furniture maker for many years. His early pieces are in the late-Regency-Early Victorian style, made in walnut or mahogany, and quietly elegant. They rivalled anything of comparable quality imported from England. Butcher spent nearly half a century producing furniture and associated pieces, changing his styles to adapt to the rapidly-changing tastes of the mid-to late-Victorian period. In the manner of woodworkers of the time, he was prepared to take on any project where joinery skills were required. He produced furniture not only for domestic use but also for government buildings, courthouses, Province House, Government House and the Central Academy. Butcher was a devout Methodist and became a Trustee of the Prince Street Chapel in 1863 until his death (Rogers, DCB).

Mark Butcher's collaboration with Thomas Alley, begun when he was 49 and a very well-established businessman, is an interesting one in that their skills were not focussed on the elements of Gothic architecture. Alley was very attuned to the Italianate style that dominated the late 1860s and the 1870s and seemed not to be much interested in the Gothic Revival. However, most likely inspired by Nonconformist Gothic Revival buildings in cities in Eastern North America, he produced a very fine exterior for the chapel; Butcher, on the other hand, produced an interior with a heavy classical cornice, that did not match the style of the exterior and which prevented the construction of acceptable Gothic vaulting. Perhaps Alley's love of the Italianate played a part here. It is true that the specifications describe Gothic vaulting, but it was clumsy and simply rose from the

cornice – a completely classical element – to a point, at the height of the top of the great window. By 1897 this poor design had become so unbearable that the cornice was ripped out and replaced with a spruce board ceiling attached to a wooden frame that simulated proper Gothic vaulting. That is the vaulting which we have today.



Butcher's pointed "Gothic" vault, springing from a heavy classical cornice above the pointed windows. Detail of 1877 photo, PARO.



The 1897 spruce board Gothic vaulting installed by the Toronto firm, Burke and Horwood. It is a successful attempt to correct Butcher's awkward pseudo-vault. Detail of photo from the Trinity United Church Archives.

A comparison of the two ceilings is most instructive and demonstrates that Mark Butcher, for all his skills as a superb cabinet-maker, had no understanding of the Gothic Revival style. But Mark Butcher was not an architect. It is possible to argue that the interior space was the work of Thomas Alley and that Butcher simply applied the decorative trim, but documents clearly indicate that Butcher was responsible for all the interior work. That involved creating a ceiling that met the bottom of the vast timber arrangement that formed the attic and supported the

extremely wide span of 68 feet in the main hall, the necessary plasterwork for the ceiling and walls, and all the trim needed for the cornice, the windows, the gallery, the pulpit, the doors and the pews.

THE SPECIFICATIONS

Reverend Brewster's claim that the chapel was to be "simple, plain, and exceedingly primitive" pales to insignificance when compared to the specifications for the new chapel which were published, mostly complete, on November 19, 1864 in *The Protestant and Evangelical Witness*, p. 2:

The whole structure is 115 feet long, 68 feet wide and 42 feet high to the eaves. The basement story is 12 1/2 feet high, 4 feet of which is under the surface line. The style of architecture is the Gothic of the 14th century [16th Century]. The material is brick, "rough cast," and Island made; and all the trimmings are Nova Scotia free stone.

The front is divided into three compartments by two octagonal Turrets, which, when finished, will be about 165 feet high. Between the turrets there is a large central window 32 feet high by 15 feet wide, with an ornamental Gothic top. Over this window, there is a large block of free stone with the date, "1863," cut in projecting figures. The main entrance at the west end is beneath, with deep recessed jambs, sliding doors, and only 6 freestone steps into the vestibule. There are also two side entrances leading into the basement and vestibule. In the rear, at the east end, there are also two entrances also leading into the basement and main Chapel. On the east side of the building [actually the north and south sides] there are seven windows both to the basement and chapel, and six intermediate buttresses, beside double buttresses at each corner. The east end has four lancet windows and four buttresses, and one large gable window. Each buttress is finished with three freestone weathering's tops, double capped, &c.

The roof is a lofty pitch, covered with slate, and the gables finished with a heavy 24 inch free stone capping. All the window and door sills are of free stone; and the whole of the windows are glazed with milk ground glass, which softens the light.

The interior of the building is finished in modern style, and so constructed that all persons both on the main floor and gallery can see the minister, and

the minister his audience. The vestibule extends wholly across the building, with convenient winding stairs leading to the gallery on each side. There are two folding doors leading from the vestibule to the main chapel; and two main centre aisles, besides an aisle by each side wall. A door opens from the aisles on each side [of] the pulpit to the eastern entrances. There are 150 pews on the main floor that will seat nearly 900 persons; all covered and cushioned with magenta colored plush.

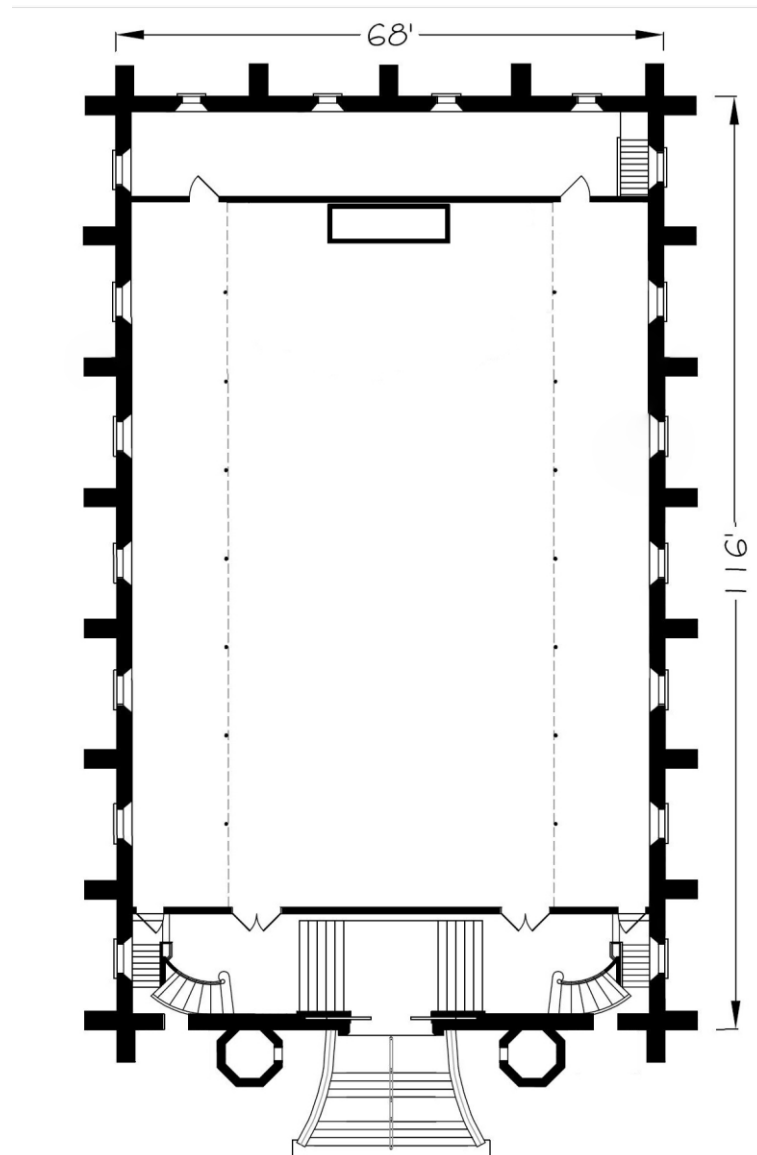

Conjectural plan showing the interior space of Thomas Alley's new Methodist Chapel. The porch would have been articulated differently in the details regarding the staircase. At the basement level on the east end, two doors led to the vestry and basement. Today they are bricked up. Plan courtesy of Carter Jeffery.

The gallery extends all round the building, and contains about 78 pews, which will seat about 650 persons, including the choir, which has its position at the eastern end, behind the pulpit.

The communion [table], pulpit, and the capping of all the pews, are of black walnut. The pulpit is plain and a fair specimen of modern architecture; it is based on a platform 18 inches high, and the pulpit floor is only 5 feet above the level of the main floor. It has a suitable sofa covered with the same material as the pews.

The ceiling is a plain Gothic, starting from the cornice 8 feet 4 inches below the eave line. The top of the large window at the west end intersects with the ceiling. The height from the main floor to the apex is 47 feet 4 inches. The whole building throughout is well ventilated by air flues which are built in each one of the intermediate side buttresses, and by two large ventilators at the apex of the ceiling, and connected with the two turrets.

The basement has easy ingress and egress, both at the western and eastern ends of the building. It is also well ventilated, and consists of one large lecture room 62 by 52 feet, and six class rooms, each 25 by 12 feet; the seats in the lecture room are comfortable and suitable for Sabbath School purposes, every alternate seat having a reversible back.

The whole building has well-arranged gas fittings, with steam pipes. The furnace is placed in the cellar; the boiler is supplied with rain water out of a tank that receives it from the roof. The whole of the heating apparatus has been fitted up by one of the most experienced engineers in the United States; it consists of the best materials, and has every improvement both for safety and economy. The cost of the heating apparatus has been about £400 currency. There is at least 3000 feet of pipe in connection with it; the boiler is tubular, sufficiently large for a ten-horse engine, and only consumes from a barrel to 1 1/2 barrel [of] Pictou slack coal daily.

The probable cost of the building will be £8000. It is, as a whole, a beautiful, commodious and convenient church and we must pronounce it to be an honour to the friends of Methodism who have reared it. Long may it stand, and ever may its watchtower be filled with men who shall prove vigilant watchmen on Zion's walls, by not shunning to declare the whole counsel of God.

THE LAYING OF THE CORNERSTONE

The cornerstone has very ancient origins, not only as the first stone that will determine the placement of every subsequent stone in the structure, but also containing information, inside and on its surface, about the time and circumstances of its being laid. It is interesting to note that the location of the corner stone with its record of the day has been lost to memory and to sight. Today it cannot be found.

The laying of the corner stone was described in detail on page 2 of the Saturday, May 30 edition of the *Protestant and Ecclesiastical Witness*. We reproduce the greater part of the article.

On Monday last [May 18], this interesting ceremony took place, as previously announced. At precisely three o'clock, His Excellency the Lieut. Governor, Mrs Dundas, and suite having arrived and taken their places, the proceedings were very appropriately commenced with the Anthem, "I have set watchmen upon thy walls," etc., which was sung in excellent style by the Choir, — Miss Preedy, the talented Organist of St. Paul's Church in this city, presiding at the melodeon. ..."



Mrs. Dundas, wife of the Lieutenant Governor. Photo, 1860, R. Porter Collection.

A bottle containing a scroll, with the names of the Trustees of the Wesleyan Society in this city inscribed thereon, copies of the London Watchman, the Provincial Wesleyan, the Monitor and other Protestant journals, the minutes of the Eastern British American Conference, etc., having been deposited in the cavity prepared to receive it, a magnificent Silver Trowel was presented to Mrs Dundas by the Superintendent of the Circuit, the Rev. John Brewster.

Mrs. Dundas then proceeded to lay the stone. Having ascertained its proper position by the spirit level, she gave the stone three taps with the handle of the trowel, saying, "I lay this stone in the name of the Father, and of the Son, and of the Holy Ghost. Amen." The Choir and Congregation immediately struck up the grand old Catholic Chant, "Gloria Patri," with thrilling effect.

The Rev. John Brewster, through whose laborious and successful ministrations and unflagging zeal the Wesleyan Body in this city is mainly indebted for this spirited undertaking, then addressed the audience to the following effect: —

Your Excellency, who has honored us on this interesting occasion; Ladies and Gentlemen of the City of Charlottetown; and my beloved Members of the Wesleyan Methodist Society; I welcome you this day, and congratulate you on the deep interest you feel in this auspicious event! ...

Not to detain you by any lengthened remarks on the character of the Church about to be erected, allow me to caution you against indulging in any hope that the building will be of magnificent proportions and of commanding aspect. It is not designed to eclipse, in beauty of architectural design, the other Protestant Churches of this City, nor outrival the conspicuous Roman Catholic cathedral. Allow me to say that the building about to be erected is to be a METHODIST CHAPEL, simple, plain, and exceedingly primitive. No tower or steeple will grace its ample proportions; no rich carvings in stone, nor fancy mouldings will attract the outer eye. Its peculiar excellence will be in its facility and convenience for preaching and bearing the Gospel of our blessed Lord and Saviour Jesus Christ. The glory of our Christian economy as Wesleyans is in the obedience we give, by the grace of God to that grand primary law of the New Testament, "PREACH THE WORD"!

...

I cannot conclude this brief and imperfect address without calling attention to yonder group of Sabbath School scholars. Our Fathers built and labored for us. Our fathers' love left to us a glorious gospel heritage. We, too, must be faithful in committing this precious charge to the rising generation. We build for our children: there they stand as interested spectators of the scene. As we look upon them, we cannot but rejoice in the fulfilment of the promise, "Instead of thy fathers shall be the children." I will now call upon the children to respond to my address by singing,— "I love the Sunday School," etc.

After the singing of this Hymn by the children,—by no means the least interesting part of the ceremony — three hearty cheers were given for Mrs. Dundas and three for His Excellency the Lieutenant Governor. "God save the Queen" having also been sung, and three lusty cheers given for Her Most Gracious Majesty the Queen, and three for His Royal Highness the Prince of Wales and his illustrious Bride, the Benediction was pronounced by the Rev Mr Sprague, and the immense congregation dispersed.

...

The scroll deposited beneath the Corner Stone of the new Church contained the following inscription:

"This Corner Stone of the Wesleyan Chapel was laid on the 25th day of May, A. D. 1863, in the Twenty-sixth year of the Reign of Queen Victoria, by Mrs Dundas, the Lady of His Excellency the Lieutenant Governor of Prince Edward Island, in the presence of a large concourse of persons: the Rev. John Brewster being the Superintendent of the Circuit, and the following brethren, who bare here unto signed their names, being the Trustees of the Methodist Society at Charlottetown: Robert Longworth, Richard Hartz, James Moore, Thomas Alley, Thomas Dawson, George Beer, Charles Young, Mark Butcher, and William Heard. Ephesians ii, 20, 21."

On the Silver Trowel presented to Mrs Dundas was the following:

"Presented to Mrs Dundas, the Lady of His Excellency the Lieut. Governor of Prince Edward Island, upon her laying the first Corner Stone of the Wesleyan Chapel in Charlottetown, P. E. I., on the 25th May, 1863, by the Trustees of the Methodist Society."

The resounding speech by Rev. John Brewster, after a disparaging remark about Roman Catholic ostentation (they had built their first wooden cathedral in 1843), goes on to say pointedly that “the building about to be erected is to be a METHODIST CHAPEL, simple, plain, and exceedingly primitive.” There could be nothing further from the truth. In fact, the new Methodist Chapel was at the cutting edge of the new Nonconformist Gothic Revival style that had begun to attract Wesleyan congregations for the past twenty-five years. (This transition was discussed in detail in the previous chapter.)

Here we have a Tudor-inspired façade dominated by a vast Gothic tracery window above a great central doorway, all flanked by slender Tudor turrets at the edges of the building. It is a large 18th Century preaching hall cleverly inserted into a Gothic chapel. At the east end was the vestry, illuminated by the four smaller lancet windows, that ran the whole width of the building. Because of the placement of the vestry the chancel wall was windowless, and the space illuminated only by the aisle windows, with their milk glass.



The new Wesleyan Chapel with more than half of the massive roof trusses erected that would create an unsupported span of almost seventy feet. The trusses were erected by Bertram Moore, who was, at the time, a citizen of Charlottetown and member of the church. 1863. PARO.

The above photograph shows the final stage of the construction of the new brick chapel: the erecting of the massive trusses that will support the roof and permit an open un-supported preaching hall nearly seventy feet wide.

The work of raising the great, principal rafters was a terrific undertaking for those days. It was a job that required the utmost possible care and skill on account of the width of the space which had to be spanned. Few buildings in Canada, even today, have the proud distinction of an arch with an unsupported span of almost seventy feet. The roof was erected by Mr. Bertram Moore, who was, at the time, a leading citizen of Charlottetown and an honored member of the church. The whole of this great work was accomplished without an accident of any kind, and the church building was completed in a little more than a year (Rogers 1964, p. 6).

With difficulty, one can climb into the attic of Trinity United and be astonished by the forest of massive trusses, arranged in the kingpost configuration, and supported with iron bolts, straps and brackets. The basic kingpost strut arrangement was extended to fill the very tall attic space with the addition of additional struts below the top ones, so that a very wide base, to accommodate the 68-foot width of the chapel space, was the result. This required an enormous amount of timber as can be seen in these photos by R. Porter.

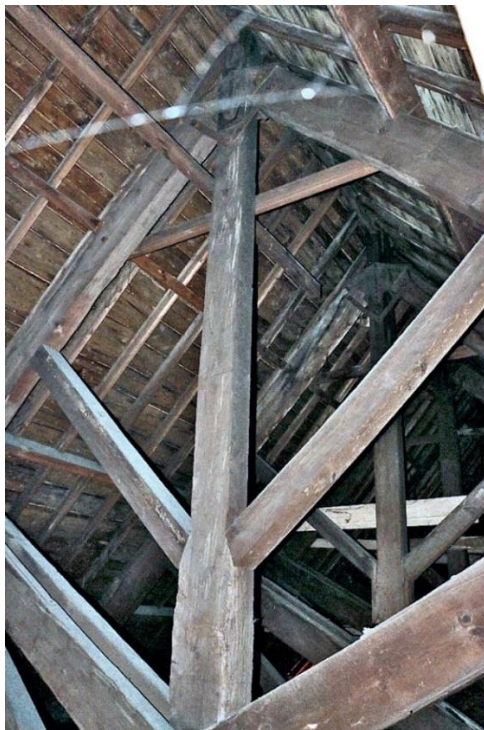



The turrets, topped by open cast-iron spires, supported what appear to be huge weathervanes that are not clearly visible in the earliest photos, but which can be seen in a watercolour by Robert Harris. The turrets themselves were topped by what appear to be semi-circular caps which must have been pierced by the stems of the weathervanes, supported inside by heavy timbers.

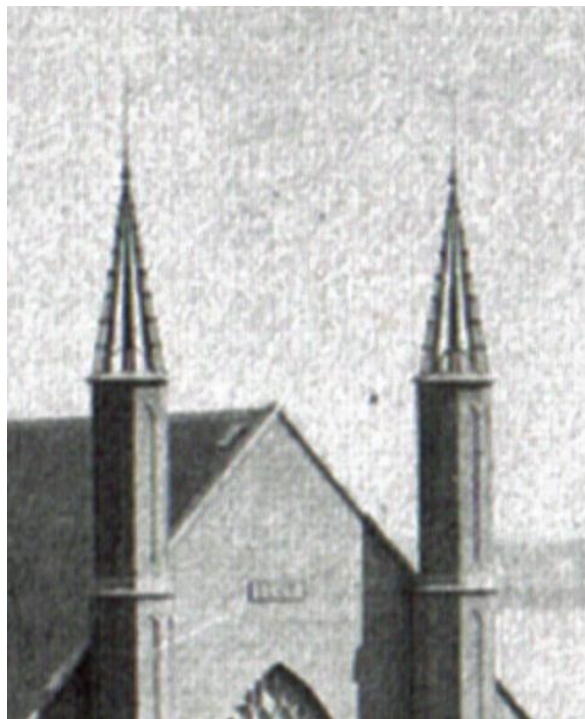

The turrets appear to have been capped by a small dome-like roof over which was placed an arrangement of cast iron elements that created an open spire. Detail of a photo from LAC and from an 1864 watercolour by Robert Harris, CCAG.

The turrets themselves are interesting to examine from within those very tall spaces. The bricks visible are crude and stained – the leftovers of firing in the kilns – and saved for use where they would not be exposed to the weather or where aesthetic considerations did not matter. The interior space is strongly reinforced by iron strapping and rods and the heavy wooden crosspiece on which rested the timbers that supported the weathervanes are still in place.



Photo: R. Porter.

These turrets were never intended, like the contemporaneous church at Tignish, to provide access to the gallery. Access to the basement classrooms was provided at the base but the upper portions were used as ventilating shafts to keep the air in the interior of the chapel fresh.

THE DEDICATION OF THE CHURCH

An ad in a Charlottetown newspaper of October 29, 1864 announces that the very extended dedication services of the newly constructed Wesleyan Methodist Church (note that the word “chapel” is no longer used) will take place starting on Sunday, November 13, with services in the morning, afternoon and evening. Evening

services are scheduled to take place on Monday and Tuesday. If that were not enough an additional full day and evening of services were scheduled for the following Sunday, November 20.

DEDICATION OF THE
New Wesleyan Methodist Church.

THE spacious Church erected by the Wesleyans of this city will be solemnly set apart to the service of Almighty God, on **SUNDAY**, the 13th **NOVEMBER**, the dedicatory services to be continued on the Monday and Tuesday evenings following, and on the subsequent Sunday.

THE ORDER OF THE SERVICES

SUNDAY, 13th, morning, half past 10 o'clock, sermon by Rev. Dr. Richey.
afternoon, 3 o'clock, Rev. Henry Pope.
evening, half past 6 o'clock, Rev. Charles Stewart.

MONDAY, 14th, at 7 o'clock, p.m., Rev. W. Ryan.

TUESDAY, 15th, at 7 o'clock, p.m., Rev. Edwin Evans.

SUNDAY, 20th, Sermon at half past 10 o'clock, a.m., by Rev. Thomas Duncan (Church of Scotland.)
afternoon, sermon to S. S. Scholars, by Rev. Howard Sprague.
evening, sermon by Rev. Richard Smith.

Collections in aid of the Trustee Fund will be made at each of the Services.
October 29, 1864.

The following description from the *Monitor*, probably written by the editor James Barrett Cooper, appears in Mellish, pp. 53-55 and is singularly lacking in any details whatsoever about the appearance of the church and its interior. We quote from the article extensively because it records the spirit of jubilation present among the congregation and focusses on the contents of the various sermons that were meant to illuminate the event in the context of Methodism.

“This spacious and imposing erection was set apart to the worship and service of God our Saviour on Sunday, the 13th of the present month (November, 1864), and the dedicatory services were continued on Monday and Tuesday evenings and on the subsequent Sunday. ...

“The opening service was conducted by the Rev. Dr. Richey under circumstances singularly auspicious. The middle of the month, proverbially gloomy, happened to be unusually mild and cloudless; the genial catholicity of the Protestant portion of the community was gratefully apparent in the aspect of the congregation, and all from the commencement to the close, appeared imbued with a spirit in hallowed harmony with the solemnity of the occasion. Selecting as the theme of his discourse Zech. vi. 12, 13, Dr. Richey expatiated on the significancy of the symbolic appellation by which Christ is here designated – on the holy and magnificent work he was destined to achieve.

“In the afternoon the pulpit was occupied by the Rev. Henry Pope, Jr., whom we were so thankful to see so renewed in physical vigor as to be able to do rhetorical justice to the very interesting and suggestive discourse he delivered on the apposite words of devout exultation uttered by the Psalmist, ‘Glorious things are spoken of thee, O City of God.’

“The Rev. C. Stewart preached a luminous, faithful and effective sermon in the evening from the memorable declaration of the Apostle, ‘Unto you first God having raised up his son Jesus, hath sent him to bless you,’ &c.

“There was a pleasing indication of undiminished interest on Monday and Tuesday – the Rev. William Ryan preaching on the former an excellent and monitory discourse based on the special and pre-eminent love of God to the gates of Zion; and on the latter, Dr. Richey calling the attention of the congregation to the glory and defence of the gospel church. On Sunday, the 20th, the weather was equally propitious and the congregations overflowing. The officiating clergyman in the morning was the Rev. Mr. Duncan of the Kirk, who gave evidence of the sympathy of his soul with the memorable announcement that Jesus Christ came into the world to save sinners.

“To the children of the Sunday School the sermon of the afternoon was addressed by the Rev. H. Sprague, who so acquitted himself as justly to claim the consideration which Paul deemed desirable, ‘Let no man despise thy youth.’ The Rev. Richard Smith was the preacher in the evening. God’s gracious observance of his advent and blessing where ever He records His Name formed the appropriate theme of the concluding discourse of a series embracing a large variety of theological instruction and practical inculcation, but all directed to one glorious subject.

“The solemnities have left a fragrance upon the mind, and the remembrance of them is sweet. May the bread thus profusely cast upon the waters, at the inauguration of this new sanctuary, be seen after many days.

“The aggregate amount collected at the services was £153.”

Thus, the new brick First Methodist Church began its long, unbroken task of ministering not only to the spiritual needs of all members of the congregation, regardless of age or station in life, but also its very energetic work of establishing schools and providing both religious instruction and classes in regular subjects to the children in its sphere of operation. The streetscape was forever changed as we can see in this Harris watercolour painted while the Greek Revival chapel was still standing. The powerful sweep of Georgian-inspired architecture starting with the huge Athenaeum on the corner of Grafton Street is rudely brought to a stop by Alley’s new brick church. Isaac Smith’s wooden Greek Revival chapel is completely dwarfed by the new structure and one cannot help but wonder what emotions Smith experienced at this sight.



Robert Harris, Methodist Chapel – with old one alongside it – in the year new one was built, watercolour, 1864, CCAG.



View of the new Wesleyan Church from the period 1865-73, showing the old wooden manse just before it was moved across the street. Library and Archives Canada.

We are fortunate to have a photograph taken the following year when all traces of Smith's chapel had been removed. It shows what the new church with its old wooden manse built by Isaac Smith looked like from the roof of Province House. It is the only known photograph of the church for the 1865-73 period.

With the completion of the brick church the Methodists of Charlottetown could look back with pride on all they had achieved in a half century of faith, dedication and effort. For the next nine years the congregation enjoyed a quiet period from the point of view of architectural activity, but soon the desire for change, for improvement, increased to the point when, with some lulls, a period of intensive renovation and building would begin that would carry on into the 20th Century. That story is told in the following chapter.

Chapter 5 – The Later History of the Brick Church: 1873-1925

In 1873, just nine years after the completion of the church, it was decided that a new manse was needed. The old parsonage, built in 1838 by Isaac Smith, was deemed to be insufficient for the needs of the ever-growing congregation and was sold to Edward Davey who moved it across the street where it now survives as 215-217 Richmond Street. Its humble Georgian, unstylish appearance, dwarfed by the new brick church, no doubt contributed to this decision as well. In line with the façade of the church, a brick manse was built in a handsome and elegant Italianate three storey design, which was now the dominant style in the city, promoted energetically by Thomas Alley, who had abandoned all pretence of being interested in the Gothic Revival, even though that style would continue to be popular well into the 20th Century.



On the left, the Bishop's Palace, begun by John Corbett in 1872 and ready for occupancy by 1875. The manse for the First Methodist Church was constructed in 1873. Although the architect has not been identified, it was possibly the work of Thomas Alley who was very busy designing and building major structures in Charlottetown in a similar Italianate style.

It is interesting to note that the previous year, the third Roman Catholic Bishop of the Diocese of Charlottetown, Peter McIntyre, had begun to build a magnificent Nova Scotia sandstone palace, across the street from his wooden cathedral, in a most elegant Italianate style with Gothic details. Despite Rev. Brewster's protestations, at the laying of the corner stone ceremony, about the simplicity of the new Wesleyan Chapel in the face of Catholic ostentation, by 1873 the current minister was ready to match the Bishop's Palace very successfully, in style if not in materials.

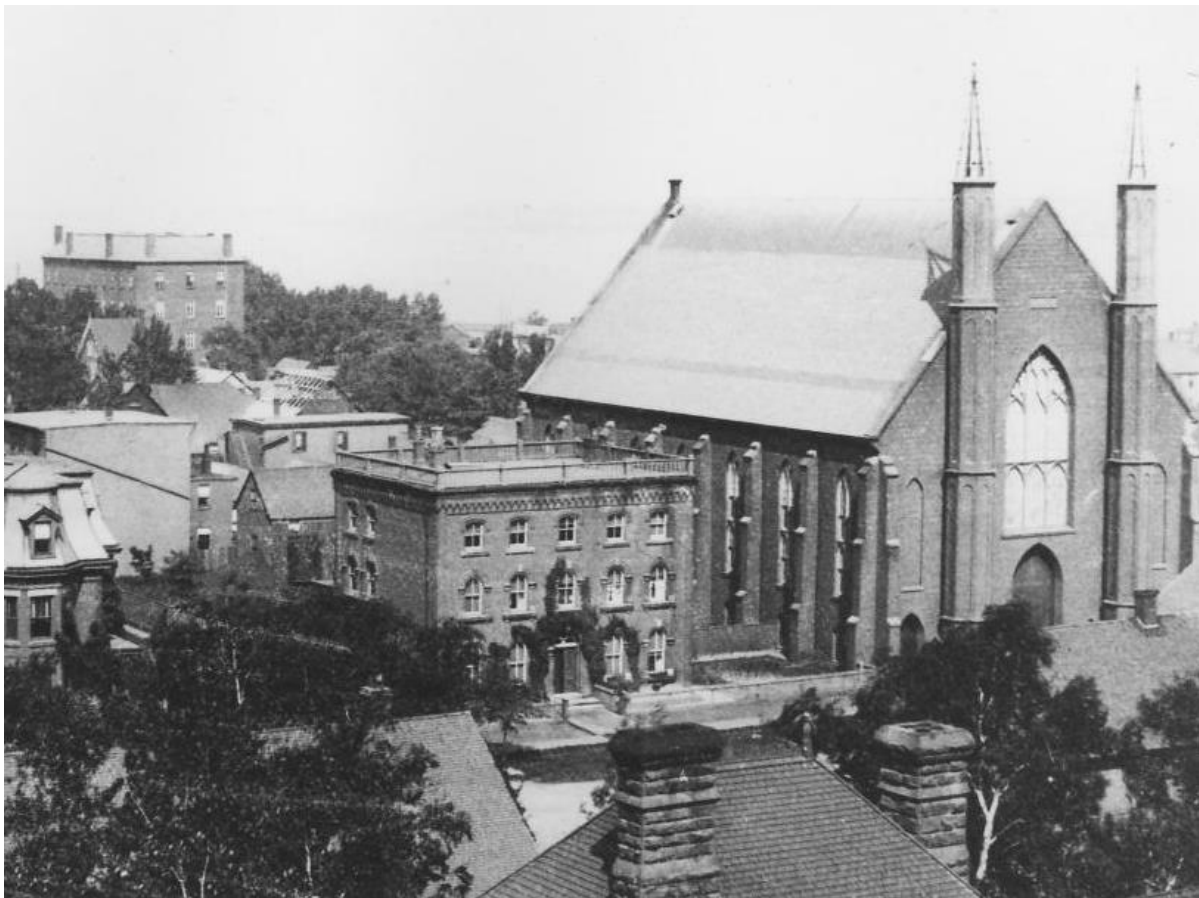

Photograph of the new manse built in 1873 in the Italianate style with round-headed windows and a balustrade on top of the roof. It is significant that its fashionable contemporary style does not match the Gothic Revival church. PARO.

The 1870s also saw dramatic changes to the interior of the Methodist church. There seems to have been general dissatisfaction with Mark Butcher's interior design and in 1877, thirteen years after the 1864 dedication of the church, it was decided to completely redecorate the interior.

At this time, it seems that the whole chancel, and its connection to the gallery area, were rearticulated so that the gallery curved in to meet a lowered seating area for the choir behind. A very clear photograph from around 1887 shows the new arrangement with the first pipe organ in place. In the July 21, 1877 issue of the *Patriot*, special mention is made of the “handsome pulpit.” It is possible that the changes seen in the photograph below were made when the first organ was installed in 1887. Further research may clarify this matter.



Photo of the interior of the Methodist church, circa 1887, showing the 1877 decoration scheme. Photo by Sterling. PARO.

The dramatic decoration scheme seen above, completely at odds with the Gothic design of the exterior, is enthusiastically described in the July 14, 1877 issue of the *Patriot* newspaper. The article is titled, simply, “Beautiful.”

The Wesleyan Church in this City has been beautifully painted, in fresco, by Messrs. Bottani and Rusca, of Buffalo, New York. The Church is 120 feet long by 68 feet wide. The ceiling is a Gothic vault, divided into panels, by

[painted] mouldings, in imitation of stucco work. The ground color of the panel is a warm blue, surrounded by a broad drab stripe. Each panel has been enriched by a border in imitation of Mosaic, and by skilful design the leaf work has been closely tied and threaded into a distinct decoration. The panels are formed by intersected mouldings, starting from a border at the apex and finishing at the cornice. The cornice has been enlarged by means of block in fresco; the top of the block is formed by flat arches divided by small Gothic panels, with a dark purple ground, at the top of which is another panel of violet, of a different form. All the ceiling has been done in water colors.

The walls of the main Audience Room and Vestibule are done in oil, in three different colors. Between each window is a panel with mouldings. Around the windows, which are Gothic, is relieved with two small panels at the top. Between the top of the panels and the cornice is a Gothic border of scroll work. The ceiling of the gallery is all divided into panels, with scroll work in each corner. The gallery front is of Gothic style, and is painted in three different colors to correspond with the walls and ceiling.

We understand that the church will be ready for opening on the 22nd inst., and that the Rev. Dr. Douglas, of Montreal, one of the most eloquent pulpit orators in the Dominion, is expected to preach on the occasion. The Rev. Dr. Lauchlan Taylor and Rev. D. D. Currie will take part in the services.

It is possible to connect the details of this very convoluted prose to what we see in the photograph. The American painters who did the work tried to make sense of the very awkward vault, whether designed by Alley or Butcher. They did not try to introduce Gothic-inspired decoration but rather stayed with the quasi-classical design of the original interior. The effect must have been striking, to say the least.

All the painted decoration above the cornice was done in watercolour, most probably a form of distemper, which derives from whitewash but with the addition of powdered chalk, lime, size and various pigments. Casein, from milk, was often added to give the mixture more stability. Distemper was difficult to apply and when dry may have shown uneven patches. Since all of this was prepared on site from raw materials, it required enormous skill to produce colours that matched in a large space like the Methodist church. Because there was no way of cleaning this finish once applied, great care had to be taken that it was not soiled by touching or

smoke from candles and lamps. It made sense to apply it to the vault. This process also lowered the cost of materials.

In all the other parts of the interior, from the cornice to the floor, oil paint was used. It would have been extremely difficult to mix oil paint that matched the soft colours of the light distemper in the vault, but it could be cleaned, especially where worshippers would brush or lean against the painted surfaces.

There seems to have been little done to the interior of the church for the next eight years, but in 1887, the installation of the first pipe organ, caused both joy and pain to various members of the congregation.



The first pipe organ installed in the Methodist church. The maker is unknown, but it was a tracker action pipe organ. Modifications to the gallery were made at this time to create a new choir loft. Photo by Sterling, 1887, PARO, Acc 3218-176.

Starting in the Eighteenth Century, accompaniment to singing in churches, both Protestant and Catholic, began to be provided by the introduction of orchestral instruments, following new developments in secular music. In previous centuries the pipe organ had filled that need, especially in the 17th Century, the time of Bach and his followers. During the English Civil War (1642-51), Oliver Cromwell ordered the destruction of most of the organs in English churches, denouncing them as Papal degeneracy. Even John Knox condemned the use of organs. People

being what they are, a desire for accompaniment to singing in church manifested itself and was fulfilled by bringing in small orchestras, consisting of stringed instruments, along with some woodwinds and brass. A flute and string ensemble was not uncommon. Such was the case with the Methodists in Charlottetown.

The Gothic Revival movement, as adapted by the Methodists, was influential in introducing pipe organs to replace the orchestras, which were increasingly considered to be too profane for Divine Worship. And so, in 1887 the church purchased its first pipe organ (Mellish, pp. 63-64). Could it have been made by Watson Duchemin, Charlottetown's own organ builder? A restored 1840 portable pipe organ by him is preserved at UPEI.

It was under the leadership of the Rev. Job Shenton, who became the minister in 1885 that a pipe organ was installed in the church. Such an innovation would have been looked upon with great consternation a few years previously, but it proved such an asset to the choir and congregational singing that it was soon accepted and greatly appreciated. It was one of the old-style tracker organs that was pumped by man-power. It cost \$2,600.00 to install. Miss Sophia Duchemin was the first organist. Later, Mr. Pope Fletcher and Miss Morris (Mrs. Hubert Beer) acted in the same capacity. Singing was always a feature of the Methodists and there were many fine voices in the church choir to lead the congregation. (Rogers, p. 9)

It seems as if there was some resistance among the clergy and in the congregation to use the organ in regular worship. In an article in the *Guardian*, August 25, 1951, that looked back on those early organ days, the following emerges:

On the following Sunday [August 30, 1891] the newly ordained and inducted minister preached his first sermon to his first congregation. This first Sunday of Mr. Fraser's ministry marked another event in the history of the congregation for on that day the organ was first used for service on the Lord's Day. For some time it had been used for midweek prayer meetings but the tuning fork still set the pitch for psalms and hymns on the Sabbath. Some older members of the congregation opposed use of the organ but most of them became reconciled to it. The first organist was Miss Margaret Rogers, now Mrs. Cecil Stewart of Charlottetown.

During the second year of Mr. Fraser's ministry the church hall and choir loft were built, with Mr. John Donald as head carpenter. Until this time the choir sat in the gallery. The hall was dedicated in 1893 with Rev. W.T.D.

Moss, afterwards a member of the faculty of the University of North Carolina, assisting in the service of dedication.

It appears from this that for its first four years the pipe organ was only used for weekday services! This shows an enormous amount of resistance by powerful people – the minister and congregation – against its installation.

From the above article it appears that in 1892 considerable changes were made to the chancel that completely removed the old arrangement of placing the choir in the gallery behind the pulpit. The gallery was modified so that a choir loft, with three rows of seats, sloping down to the back of the pulpit, was constructed. An ornamental railing separated the new pulpit from the choir and a large three-seat bench was placed in front of it and behind the new pulpit. This bench is now on display in the church.



The 1892 renovations to the brick church created a choir loft accessible from the ground floor, with the seating placed in front of the organ, rather than at the sides. John Donald was head carpenter. A massive upholstered bench for the preachers was installed and can be plainly seen. This bench is now on display in the church. Photo: Trinity United Church Archives.

For some time there appears to have been a general dissatisfaction with the way the interior of the church was articulated. The very expensive 1877 painting scheme

may have caused temporary satisfaction to the congregation which had been so unhappy with Mark Butcher's original scheme, but this would soon change.

THE MASSIVE 1894-99 RENOVATIONS



The interior of the brick church after it was completely renovated to make it look Gothic, with the addition of suitable columns at the front and with ribbed vaulting supported by Gothic-style brackets along the walls. The chancel was given a tri-partite look by the application of three tall Gothic bays, extending it to five bays with the width of the galleries. Photo Trinity United Church Archives.

During the pastorate of Rev. G. M. Campbell (1894-99), the interior of the church was completely changed. The old plaster ceiling was removed and the old windows were replaced by more modern styles. (Johnson, p 224)

Rev. G. M. Campbell must have been a man of extraordinary vision, taste and energy. He appears to be the person who identified the hopeless arrangement of the

interior of the brick church and who saw the need to make it consonant with the Gothic exterior. Rev. Campbell must also have been very up-to-date with trends in the Methodist church that involved the adoption of traditional stained-glass windows. It is during his time that stained glass was first installed in the church. This renovation was a major project, the most extensive since the chapel space was first set up in 1864. The awkwardly-vaulted plaster ceiling was ripped out and a new ceiling, adapted to the Gothic style was installed. The mess and disorder must have been enormous. This involved ripping out Mark Butcher's cornice and installing suitable brackets from which sprung Gothic ribs that would meet at the apex of the ceiling, thus creating an imitation of stone vaulting. The spaces between the ribs were filled with narrow spruce boards which provided vastly improved acoustics in the days when a human voice had to fill a church space with clearly audible unenhanced speech.

The new Saint Paul's Church, built by William Critchlow Harris in 1896, had spruce-covered vaulting because Harris, who was deeply interested in church acoustics, tested his theories in the church. It seems likely that Harris' acoustic theories influenced the choice of spruce for the ceiling.

In 1897 the Toronto firm, Burke and Horwood, were engaged to make renovations to the church. A wooden ceiling was installed and the choir changed to seat several times its then membership, bringing it up to fifty. The two vestries on either side of the organ were furnished to be used as adult bible classes in addition for their use for the choir on Sunday. The plans for renovations were on view at Mark Wright and Co. (Rogers, p. 34).

By the end of the century the work was complete. The new interior was painted in a light colour, judging from the photograph. The effect is very fine and now the interior of the brick church is in accord with its exterior. Everywhere there is the mystery of Gothic, with its soaring arches and the quadripartite vaulting achieved in the vaults above the gallery ends. This also celebrates the end of the four-sided gallery, with its discomfort experienced by the choir placed behind the preacher, who only saw the top of his head. The quality of light in the church also underwent a dramatic change as the first stained glass windows were installed.

THE INTRODUCTION OF STAINED GLASS WINDOWS

The subject of the stained-glass in Trinity United Church has been dealt with extensively in a catalogue by Reginald Porter, *The Stained-Glass Windows at*

Trinity United Church Charlottetown, written in 2015. There each window is documented, and the iconography is described and interpreted. What follows is a summary taken from this work.

When the First Methodist Chapel was constructed in 1864 the specifications, according to the *Protestant and Evangelical Witness*, 19 November 1864, require that,

“the whole of the windows are glazed with milk and ground glass which softens the light.”

The two windows that survive at either end of the vestry are probably remnants of this original glass.

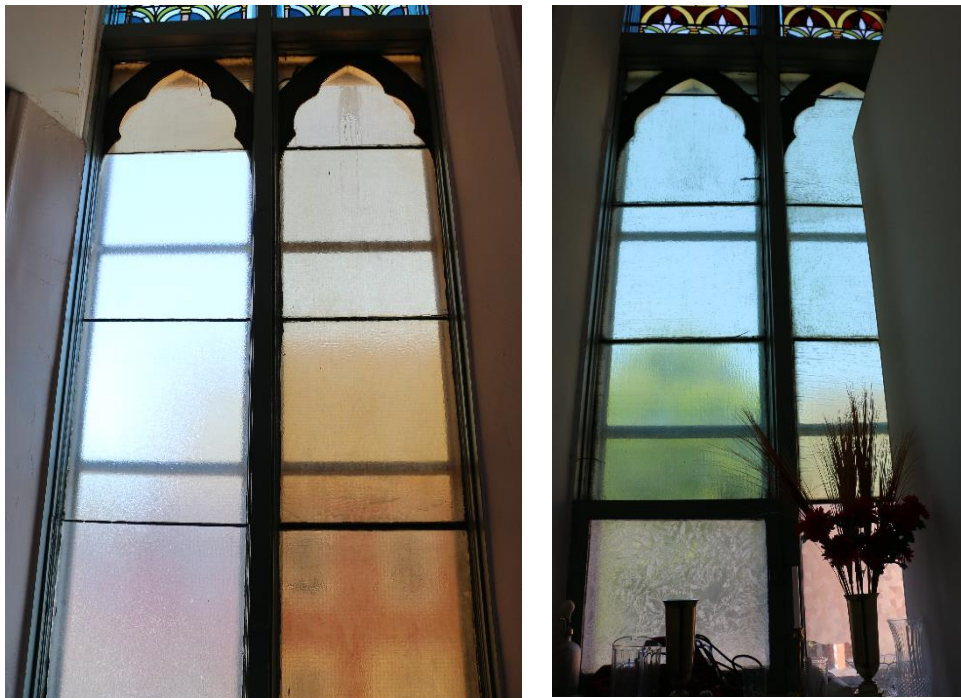

The two vestry windows with remnants of the original milk and ground glass installed in 1864.

The article continues with its description of the windows that are found in the church:

Between the turrets there is a large central window 32 feet high by 15 feet wide, with an ornamental Gothic top.

...

On the east side of the building [actually the north and south sides] there are seven windows both to the basement and chapel, and six intermediate

buttresses, beside double buttresses at each corner. The east end has four lancet windows and four buttresses, and one large gable window.

This magnificent early 20th century photograph indicates the distribution of the openings that would later be filled with traditional stained glass.



In a century these windows would be filled with stained glass. c1910. Trinity United Archives.

It is important to note that from the very beginning all the windows that lit the preaching room were divided into two sections in order to place the galleries against them. This division is clear in all the windows seen in this photo. When, as an unforeseen event, it was decided to fill these windows with stained glass in the late 1890s, the logical divisions for narrative units were already in place. The great West window, for example, is divided precisely where the sloping back of the gallery meets the wall. When this window was filled with stained glass, only the top part was treated in that fashion. The bottom section, split in two by gallery construction, was to remain with its original glass as late as the 1970s, when a most unsuitable solution was found that destroyed the integrity of a fine modern window.

The first window in the brick church to receive stained glass was the upper half of the great West window. It was manufactured by the eminent firm of Joseph McCausland and Sons in Toronto. Its main subject was the Doxology, "Praise God from whom all Blessings flow," and this inscription forms the base on which the upper portions rest. Above these words are pictures of three angels playing various musical instrument in praise of God. Above the angels, in a complicated arrangement of tracery, are various traditional Gothic ornaments, all capped by a magnificent Dove of the Holy Ghost made of blue flashed glass.

This is a very fine window, and more than all the other windows, fills the church with glorious light. Its date is difficult to ascertain precisely. Robert McCausland, the present director of the company (personal communication), believes it to date from the 1880s, but our research so far indicates that this dates to Rev. Campbell's major renovation of the church interior. Unfortunately, the window is unsigned. We do know that it has to date from before 1897 when the company split its responsibilities and Robert McCausland took over the church glass division and began to sign and date his windows.

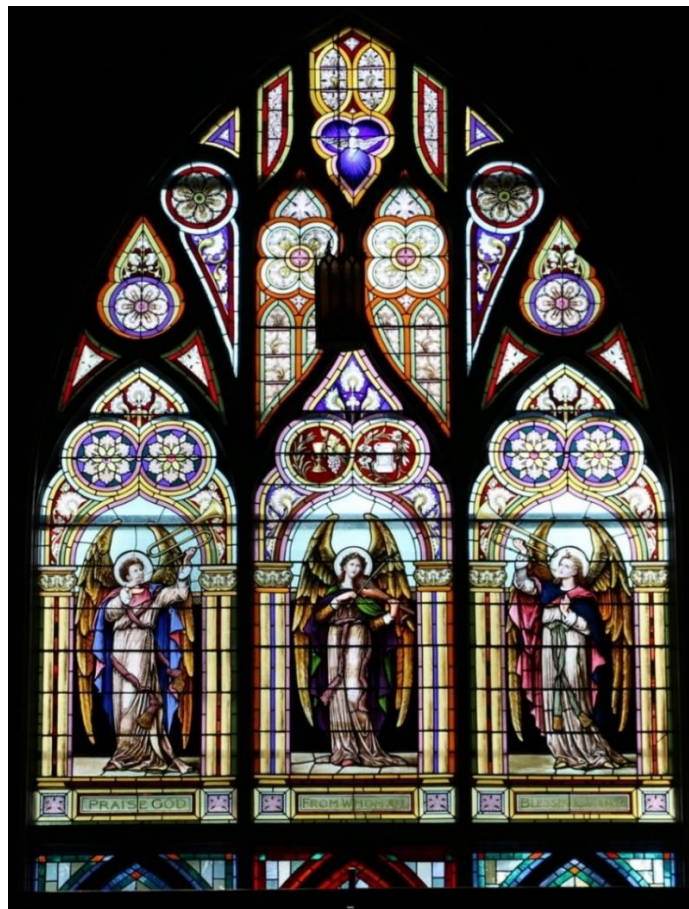

Photo by Reg Porter

The next stained-glass project at the Methodist church consisted of the three windows under each side of the balcony at the front of the church. They are all signed by Robert McCausland and date from post-1897 to 1903.



North aisle window 5
Good Shepherd & St. John
Robert McCausland Co.
Post 1897



South aisle window 5
Jesus doing good. [Acts 10:38]
Robert McCausland Co.
Post 1897



North aisle window 4
Jesus visits Mary and Martha
Robert McCausland Co.
Circa 1898



South aisle window 4
Light of the World and Faith
Robert McCausland Co.
Post 1897



North aisle window 3
Allegory of Hope and Love
Robert McCausland Co.
Post 1897



South aisle window 3
Presentation in the Temple
Robert McCausland Co.
1903

1901-03 REPAIRS TO THE TURRETS

By 1901, the force of the weather, leaks into the masonry and lack of maintenance, had caused serious problems to develop in the top level of the turrets that supported the cast iron spires. In the April 4, 1901, Trinity United Church Archives, File F-2, there is a letter from Mr. Lowe (of Lowe Brothers) to the Board of Trustees indicating that the original turret tops were to be taken down and reconstructed according to 'the sketch' (sketch was not included in the notes) for \$150.00. In fact, when the turrets came down in 1902/1903, Lowe Brothers charged \$399.66 for the work.

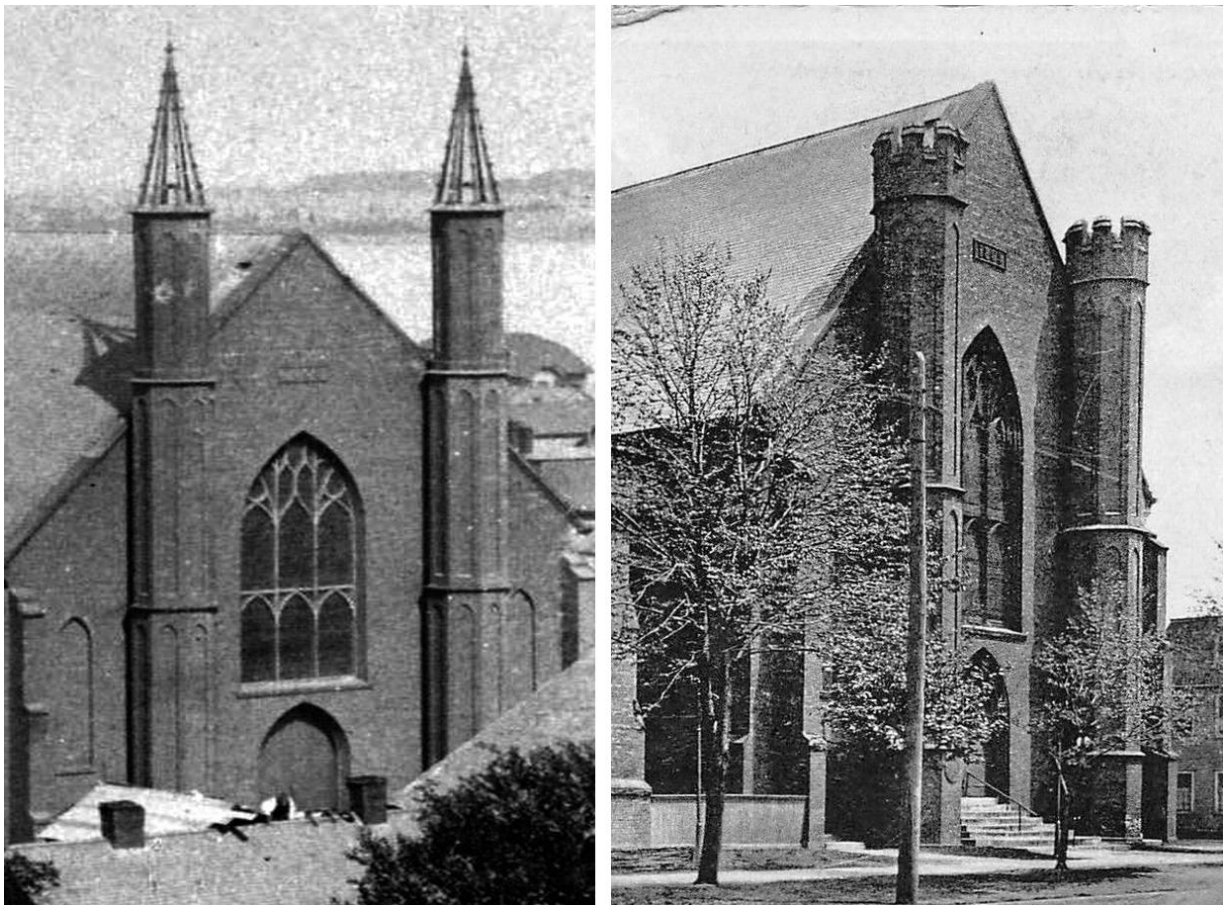

Detail of an 1865 photo showing the original turret top arrangements compared to the modifications made by Lowe brothers in 1901-03, as seen in this detail from a contemporary postcard.

The result was a severe assault upon the integrity of the original design, whose inspiration went back to the 16th Century. The façade required that the towers rise above its apex, and the open-work iron spires added grace and fantasy to the whole design. Mr. Lowe's answer to the problem was to remove the top storey of the

three-story turret and cap what was left, well below the top of the façade, with small octagonal battlements. This new arrangement of using battlements on such slender turrets was not wrong; the fact that a whole storey was missing from the turrets created an eyesore that, with modified caps, we are still living with today.

1904 - THE LONGWORTH WINDOWS

The next major project at the Methodist church changed the quality of light in the body of the hall by the addition of two magnificent 13 x 9-foot windows on either side of the organ. They were in memory of Robert Longworth and his wife, donated by their son Israel Longworth, who was on the first board of trustees, active in the Sunday School, a merchant and the first president of the Merchant's Bank. The window on the left is in memory of Mr. Longworth, and on the right, Mrs. Longworth.

The installation of these two magnificent windows required an extensive amount of alteration to the brick east wall of the church. First (two top plans) the original four lancet windows that had lit the long vestry wall had to be bricked up in order that new large openings could be made in the wall to accommodate the Longworth windows (bottom plan). This was so the large wall would not be destabilised by all this interference. The Longworth windows cleared the tops of the lancets by several feet and were given support by the three brick buttresses that ran along the back.

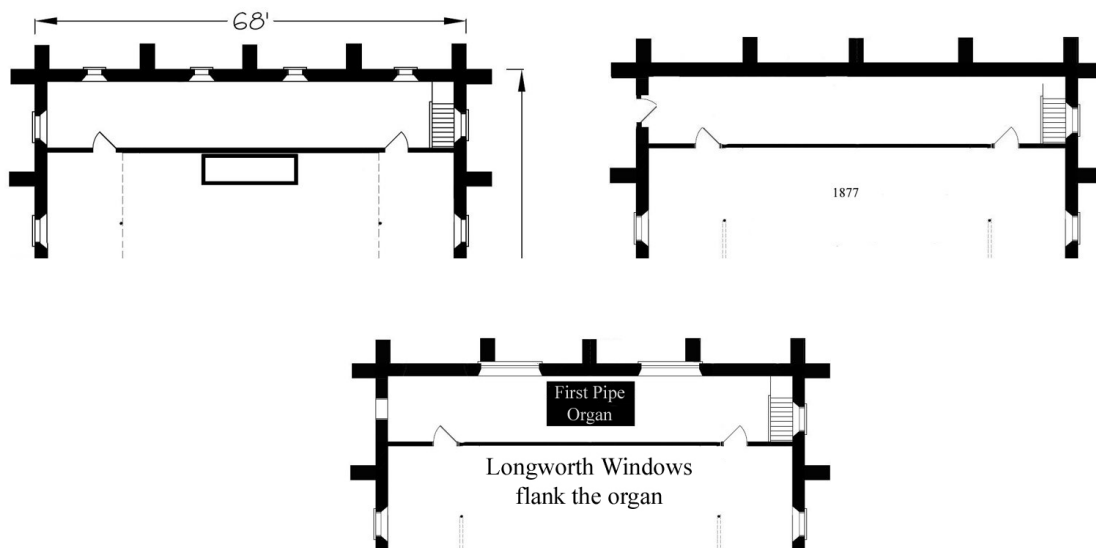

Basic plan courtesy of Carter Jeffery.

Curiously no photograph seems to have survived that shows the new windows in place on either side of the organ. An urgent search for such an image continues.



Window to the Memory of Robert Longworth, with the title of "But whatever house you enter, first say, 'Peace to this House'" (Luke 10:5)

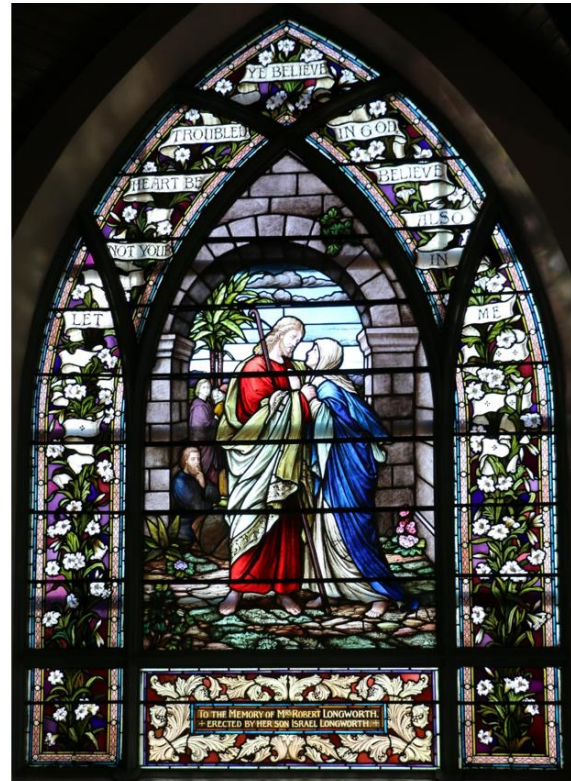

Window to the memory of Mrs. Longworth, with the title of "My peace I leave with you, peace I give unto you: not as the world giveth give I unto you." (John 14:27)

Photos by Reg Porter.

In comparison to the drama of the installation of the Longworth windows in 1904, other events that are recorded seem very small by comparison. Rogers (1964, p.35) tells us that the man who inflated the large bellows of the organ was paid \$21.00 for his services. Another tidbit from Rogers tells us that the new minister, Dr. William Dobson was such an energetic speaker that he could not be constrained, in his pacing up and down by the pulpit, so it was removed, and a small table placed nearby.

For the next six years the church and its furnishings enjoyed a rare period of stability as we have not discovered any evidence of new projects. This was to change drastically in 1910 when it was decided to purchase a new pipe organ for the church, the old one now being deemed unsuitable.

The sign of things to come is heralded by this article on page 4 of the *Guardian* of April 30, 1910:

The large stained-glass windows at the rear of the First Methodist Church are being removed and will be placed some feet further apart. This change is made necessary to provide for the placing of the new organ which will be much larger than the old one. The new organ is expected to be here the first week in June and negotiations for the disposal of the old one are now under way.

Just six years after a very major intervention in the east wall had removed the original lancet windows to cut new, very much larger, openings for the Longworth windows, this whole project was to be started all over again! There was really no choice as to where they should go – as close to the outside walls as possible. Now these windows, which, at the wish and munificence of the Longworth family, had made the chancel a magical place full of colour and inspiration, were to be banished to the gallery ends where none of their exquisite detail could any longer be seen by the congregation.

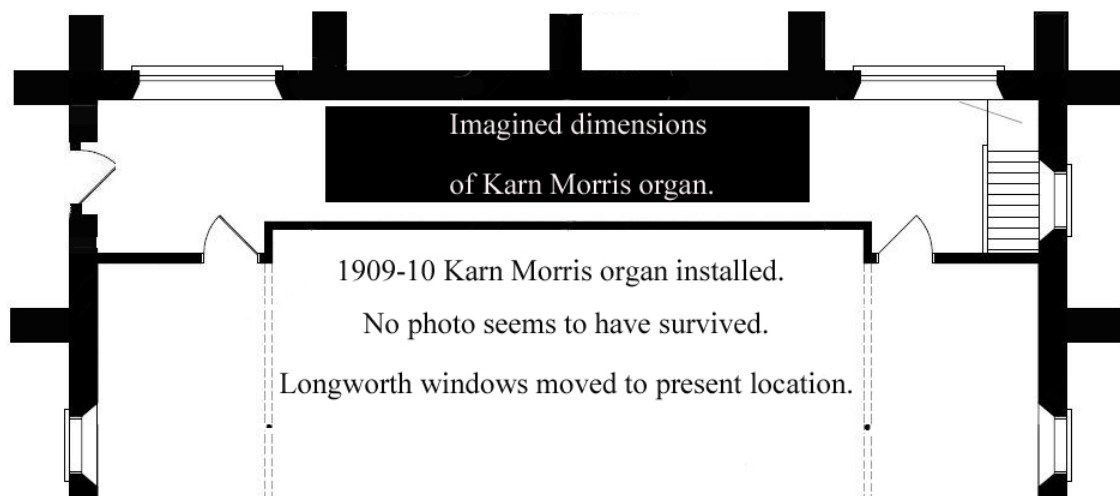

Basic plan courtesy Carter Jeffery.

The drama to be seen in the brick on the east end of the church reached its present articulation at this time, and it is what we have today. Note that the large pointed attic window has also had to be bricked up to provide the stability needed in the long-suffering wall.

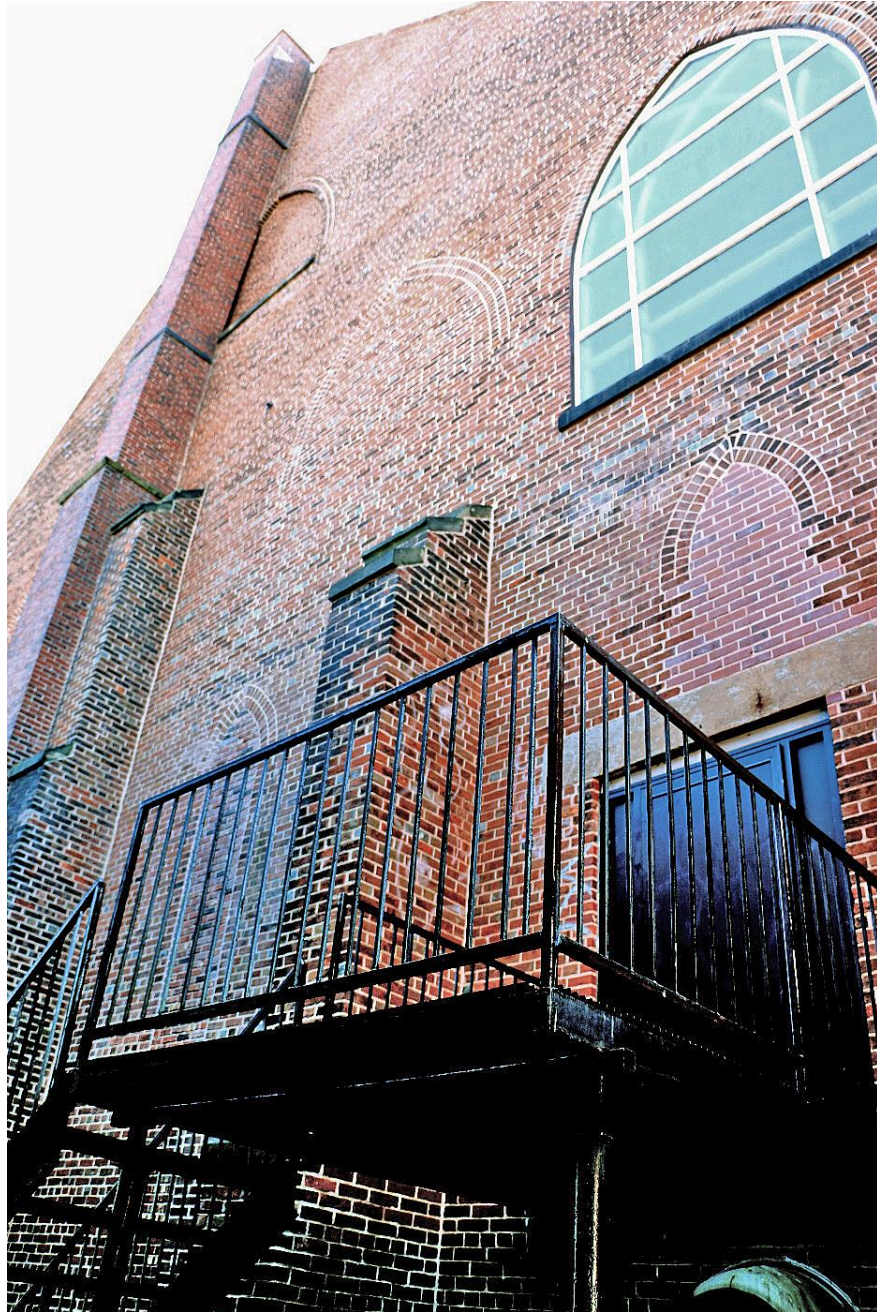

With the Longworth windows out of the way, work could begin on installing the new Karn Morris tracker action organ purchased from that company in 1910. D. W. Karn Company was a very energetic and progressive firm with its extensive factory on Dundas Street in Toronto.

(It is distressing that we seem to lack any photograph of the interior of the church from 1910, when the Karn Morris pipe organ was installed, until the installation of the Great Casavant organ in 1955 – a period of 45 years!)

In the November 17, 1934 issue of *The Guardian* we learn that,

For a number of years the “Ladies Aid” of the church were raising a fund to erect a new Sunday School building and when the Hartz Hall was given to the church, the donors stipulated this money should be put into a fund to procure a pipe organ for the church. This fund, amounting to about \$6000.00 and an additional amount of about \$3000.00 was subscribed to procure our present organ.

A description of the installation of the new Karn organ appeared in *The Guardian* on September 24, 1910, on page 4.

The new organ for the First Methodist Church is being installed by H.A. Karn, of Woodstock, Ont., and W.R. Shute, of Halifax. The old organ has been removed and shipped to Souris, where it has been purchased for the Catholic Church. Music in the church Sunday was furnished by an orchestra. The new organ was manufactured by the Karn-Morris Organ Co., of Woodstock, Ont. It is the largest on the Island and one of the largest in the Maritime Provinces. It will cost when completed, \$7,000. It will stand 32 ft. 3 inches high and will be 33 ft. wide, occupying a large part of the space in the east end of the gallery. It has 2600 pipes and three manual key boards. Its tonal scheme admits of great power and variety. The material used in its construction weighs about 21 tons; all except three and one half tons have now arrived and it will take about three weeks to assemble the parts. There are over thirty stops and it is twice the size of the old organ. The bellows are operated by a water motor in the basement. An interesting feature is a set of chimes of twenty notes. The opening recital will be given by Prof Wheeldon, of the Metropolitan Methodist Church, Toronto, successor to Dr Torrington one of the most skilled organists in Canada today.

The original cost estimate seems to have gone up by \$2000 to \$9,000. One half of this was paid by the Ladies Aid Society of the church (TUC Archives F-2). On October 19, 1910, the Karn-Morris organ was inaugurated.

The year 1910, when Rev. H.E. Thomas minister, was blessed with a superabundance of major projects. As well as the installation of the new organ, two new structures were erected on the grounds of the First Methodist Church – a new brick manse and Hartz Hall. The new brick manse, at what is now 220 Richmond Street, was built to replace the 1873 Italianate brick manse that had been

demolished to build Hartz Memorial Hall. Charles Benjamin Chappell, the great grandson of Benjamin Chappell was the architect and it was built by the firm of Chappell and Hunter. Some of the design elements were taken from the Romanesque Revival style that was popular at that time. The original plans for the building still survive. The design is sophisticated for such a compact building, with elegant articulation being provided by two bays with round-headed windows, a projecting gable, and a fine, well-defined wooden porch.

The new building was designed by Charlottetown architect, Charles B. Chappell. The congregation accepted the tender of \$2625.00 offered by the builder, B.D. Huntley, and the Manse was completed in August 1910. The 7 December 1910 issue of the *Daily Examiner* newspaper described the Manse as having hot water heating and every modern convenience. The article mentions Mr. D. Howlett “giving it the finishing touches”. The first occupant of the house was the Reverend Herbert E. Thomas who served there from 1907-1911. The Manse is still used by the church to this day. As a well preserved example of a brick Romanesque Revival influenced home in Charlottetown, the Trinity United Church Manse has many round arch windows with decorative key stones, moulding, and sills (Canadian Register of Historic Places).

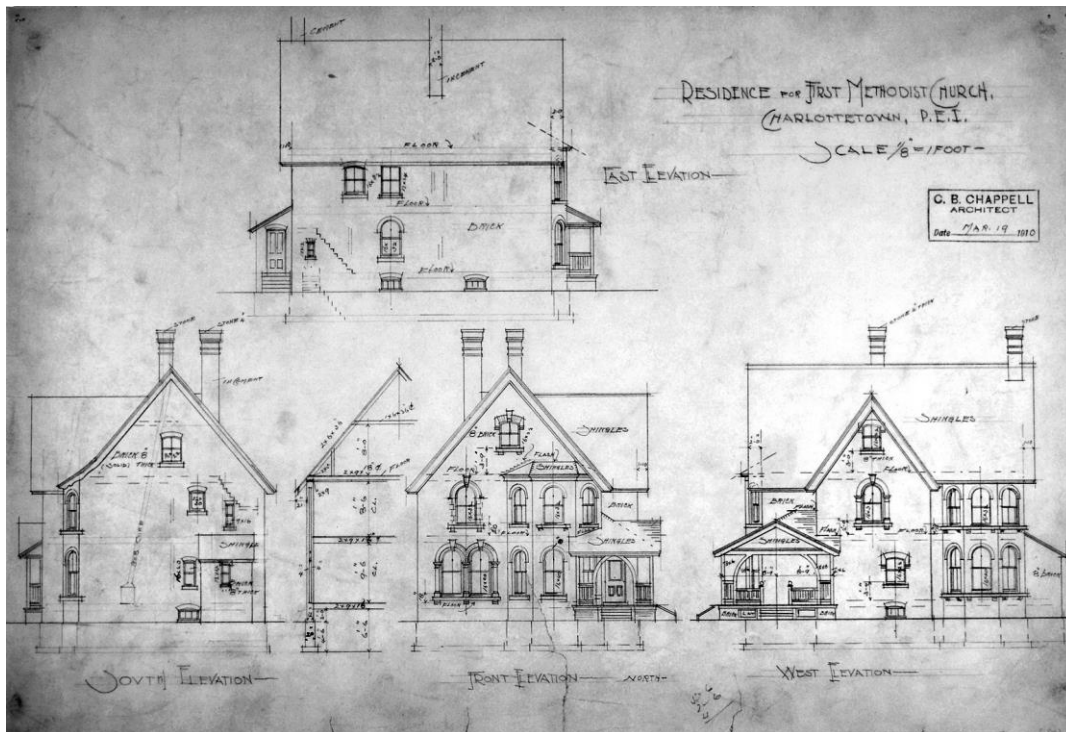

C B Chappell's 1910 elevations for a new brick manse on Richmond Street for the First Methodist Church. PARO, Acc3607-File 174 02.



Chappell's 1910 brick manse as it appears today. The architecture has been, overall, preserved in its original state. Photo: Reg Porter.

Heartz Memorial Hall

In 1910, Charles Benjamin Chappell designed and built the Heartz Memorial Hall on the corner of Prince and Richmond Streets. Its architectural style is very difficult to pin down because of its eclectic nature. The heavy masonry, some of it rusticated, suggests that it is part of the Richardson Romanesque Revival movement, then popular on the Island, but the pointed Gothic windows and buttresses suggest that an effort was made to make it match the Gothic Revival style of the First Methodist Church. The result was heavy and oppressive and menaced the simplicity of the church.

Heartz Hall competed with the First Methodist Church in seeking to dominate the block with its strong horizontal shoulders from which the richly decorated gable sprung. Had the church not lost a storey in its towers it might have maintained its dominant position by sheer height.

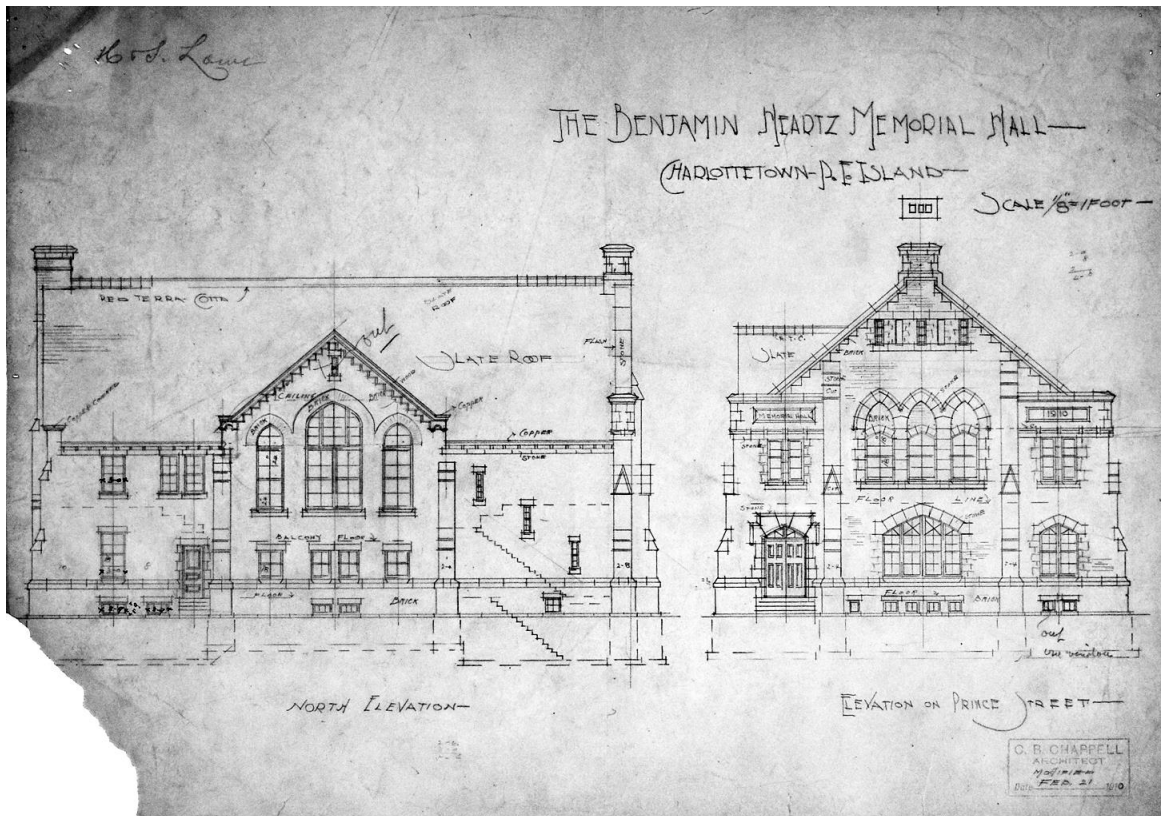

C B Chappell, north and west elevations for Hartz Hall, 1910, PARO.

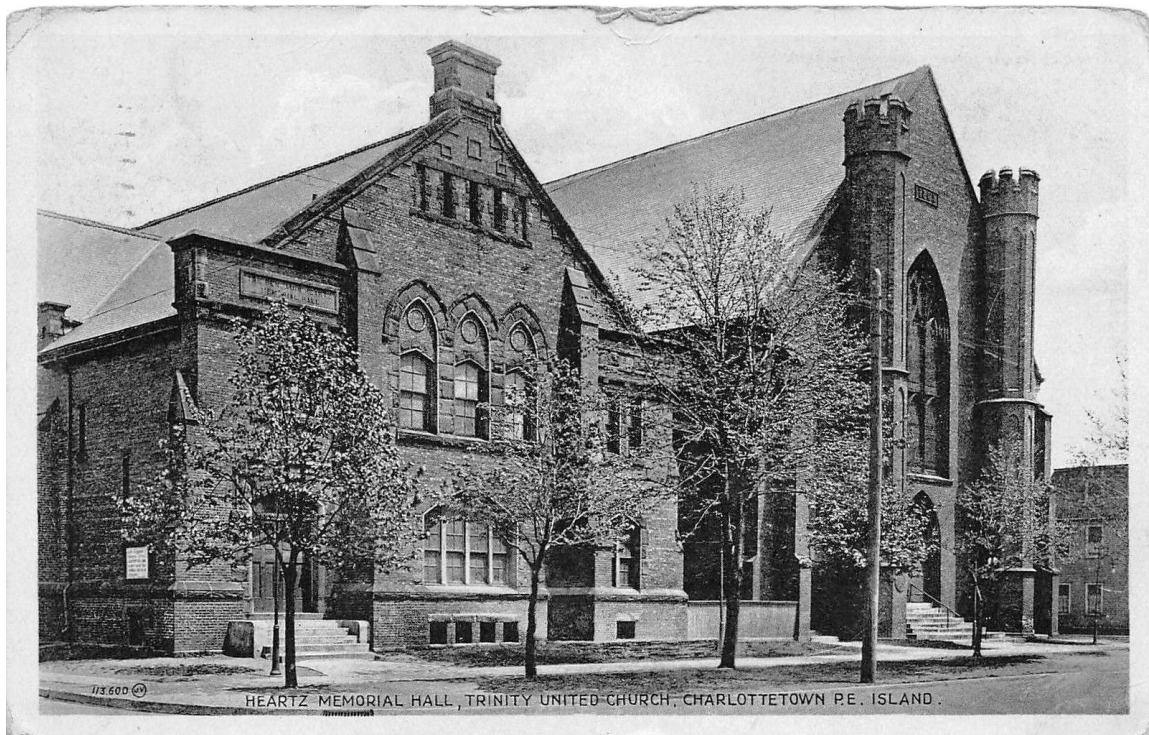

C B Chappell - Hartz Hall, built in line with the First Methodist Church, and echoing, in a Romanesque concept, the Gothic elements of the church. Postcard, circa 1911.

This quite extraordinary gift to the Congregation was celebrated in the *Patriot* newspaper on July 5, 1911, one day after the dedication of the building. A summary of it is found in Rogers 1964, pp 22-24.

The inscription on this architecturally beautiful building reads as follows:

“This building was erected in 1910 by Richard and Frank Hertz in loving memory of Benjamin Hertz — Born 1845. Died 1904”.

...

According to the news releases the dedication service of The Hertz Memorial Hall was held on July 4, 1911. The “Patriot” newspaper of July 5, 1911 devoted over 6 columns to the event.

“With eloquent oration, a bright musical program, and the usual simple but impressive and significant ceremony used by the Methodist Church on such occasions the Benjamin Hertz Memorial Hall was formally opened last evening, and dedicated to the sacred and noble work for which it was planned and erected”.

The Hall was a gift to the Church from the Hertz Family. Richard Hertz bequeathed the sum of \$11,000 toward it and the balance, the sum of \$6,000 was donated by the Hon. Frank R. Hertz, his grandson. Benjamin Hertz died on December 28, 1904 at the comparatively early age of 59 years leaving to mourn his wife, an only son, Frank R. Hertz, his aged Father and Mother, two sisters Mrs. F. P. Taylor and Mrs. Sarah E. Perkins and one brother Rev. Dr. Hertz of Yarmouth who delivered the oration at the dedication ceremonies. His closing sentence was “that this building dedicated today should be regarded as a monument to one God for the conservation of the highest interests, the development of the noblest ideals in Church and State, and the upbuilding of the Kingdom of our Lord and Saviour, Jesus Christ”.

The following resolution moved by Colonel F. S. Moore and seconded by Mr. James Paton was unanimously carried:

“Whereas for a great many years the work of the Church has been greatly hampered for want of a suitable building, modern in its appointments and equipment and sanitary in its conditions, and whereas this long felt want has been supplied through the munificence of the representatives of one of our

oldest and most honored families therefore resolved that the best thanks of the officials, members and adherents of the First Methodist Church of Charlottetown be and are hereby tendered to the executors of the estate of the late Richard Hartz and to Frank R. Hartz, Esq., for this gift to the church of the beautiful building so complete in all its appointments and so fully equipped for Sabbath School and Social and religious services to be known as the “Benjamin Hartz Memorial Hall”, also to Rev. W. H. Hartz, D.D. for his kind interest and valuable assistance and for the handsome platform furniture, consisting of chairs and lectern

In 1923, when Rev. W.M. Ryan became minister, part of the basement of the brick church was redone and was connected, with a raised floor, to the basement of Hartz Hall with a broad brick passage which provided classroom space and a large social room. The cost was \$7,000 which was all subscribed the evening the social hall was opened. (*The Guardian*, November 17, 1934).

Hartz Memorial Hall was destroyed by fire in 1969.

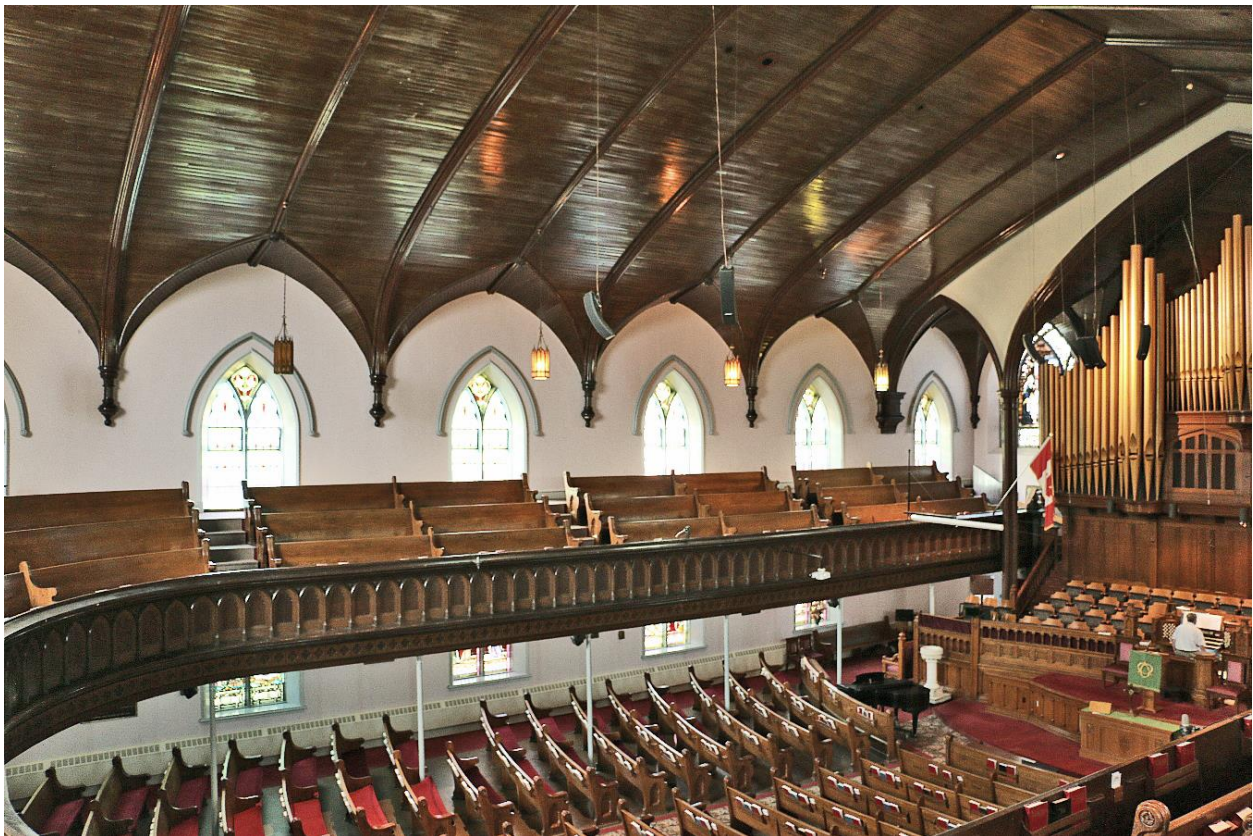

The interior of the First Methodist Church as it appears today, showing 1915-19 improvements to the seating and the appearance of the ceiling.

1915-19 - ANOTHER EXTENSIVE RENOVATION OF THE BRICK CHURCH

The pastorate of R.G. Fulton (1915-19) coincides with the horrors of World War I and another very extensive renovation of the First Methodist Church. Electricity was introduced to the building and an up-to-date heating plant was installed to replace the original heating system of 1863. The painted spruce ceiling, of 1894-99, was now completely grained with a light and dark oak effect to give life to the wood. The loss of brightness in the church due to this dark ceiling was compensated for by the new electric chandeliers. The walls were painted as well. The greatest expense was the introduction, in the preaching hall, of a complete set of new pews built of quartered oak and constructed to curve around the pulpit. These seats survive to this day.

In the Saturday, November 4, 1916, issue of *The Guardian* on page 4, there is a detailed account of these new renovations to the church.

FIRST METHODIST CHURCH TO RE-OPEN SUNDAY, NOV. 12

The congregation of the First Methodist Church of this city are to be congratulated upon the extensive improvements that have been made in the interior of their grand old church. The auditorium, which is one of the finest in Canada has been thoroughly renovated and painted and re-seated with up-to-date circular pews, built of quartered oak and beautifully finished in the natural wood. A new heating plant of the most improved plan has been installed, and a modern electric lighting system has been placed in the building. The whole church presents a fine appearance, each part blending and harmonising with the other and bringing out with splendid effect the grandeur and beauty of this noble sanctuary.

.....

The extensive improvements now made, which will cost about \$9,000, reflect great credit upon the Rev. Mr. Fulton, the pastor of the church, the trustees and the members of the congregation, who so generously subscribed for re-seating and heating the church, so necessary for the comfort of the worshippers as well as the beautifying and adorning of the sanctuary of God.

The pews were supplied and put in place by the Valley Seating Company of Dundas, Ontario, and the heating plant was installed by Bruce Stewart &

Co., of this city. The painting and graining of the whole interior of the church including the gothic ceiling, which is done in light and dark oak, is the work of A. L. Howatt & Son, the well known painters of Charlottetown.

The church, which has been closed for the past four months, will be re-opened for Divine Service on Sunday, the 12th inst. – the anniversary Sunday of its opening, fifty-two years ago.

The Church Improvement Account for the time had the following notations:

New Seating: \$3,202.00
 Heating and plumbing: \$3,145.63
 Alterations to gallery and basement: \$647.75
 Electric Lighting: \$399.61
 Organ repairs: \$57.99
 Hymn books: \$112.13

Looking back over the previous half-century it is with admiration that we observe the relentless drive shown by the Congregation of the First Methodist Church in its desire to build, and then to perfect, and then to enhance, their brick church so that, in its up-to-date splendour, it was fully prepared to disseminate the word of God and to engage in every possible aspect of its many educational programmes.

This was the last major project to the fabric of the First Methodist Church. In June of 1925 the church united with Presbyterian members of the two congregations of the Kirk and Zion to join the United Church of Canada. This union was called Trinity United Church, “Trinity” having been chosen by the congregation.

Our story ends here as the era of Methodism is over. However, in the years ahead work on what was now Trinity United Church continued in many directions and, to make the story as complete as possible, we will document the major projects of this period in the Appendix.

Chapter 6

Ancillary Architecture in Methodist Charlottetown

Not all Wesleyan Methodist architecture was concerned with the building and improvement of the various Methodist chapels. This further chapter is necessary to show how and where they extended the boundaries of their mission beyond the chapel itself.

The Methodists believed passionately that their mission involved the education of youth, not only in the tenets of their faith but also in the practical skills of reading, writing, arithmetic, music and the domestic arts. This would result in the rental or construction of ancillary structures in Charlottetown. Beginning very early, even before they had been able to build their first chapel in 1816, efforts, in a private capacity, had been made by Mrs. Hannah Bulpitt, the wife of the first minister to dwell in the city, to provide basic education from her home.

The Methodists were not the only denomination to be concerned about education and, to place events in perspective, in this chapter we will mention the major educational activities among the Anglicans and Catholics and note the architecture that resulted from this work. Starting with Governor Fanning, plans were made for a public education system funded by the government. Early attempts failed, and it took a long time for public education to become a reality in the city.

In Benjamin Chappell's *Journal* we learn that Rev. James Bulpitt arrived in Charlottetown on August 1, 1807, after having first landed at Bedeque.

The Governor received the new minister with kindness, inquired whether the Methodists would fight for the king, and allowed him to preach in the Court House or the unfinished church [the 1800 Anglican and Scottish church in Queen's Square], where a large congregation of the most respectable inhabitants listened to him. The rector, who officiated in the morning, attended the Methodist services with his family, in the evening; and his eldest son soon became a member of the class. Soon after his arrival Mr. Bulpitt reported the number of members of society as fifty, fifteen of whom were resident in the town. There was preaching on Wednesday evenings at

Theophilus Chappell's house, and sometimes at his father's. Prayer meetings were held on Sunday mornings in the large room of Mr. Bulpitt's house, where Mrs. Bulpitt conducted a day school on week days. (Mellish, p. 12).

The house must have been relatively large to accommodate a class of students.

Mrs. Hannah Butterfield Bulpitt, wife of the Rev. James Bulpitt, opened a private school in her own house in the year 1807. This was the first school on the Island taught by a lady. Mrs. Bulpitt was assisted in the school at various times by Mr. James Cambridge, by her son, Mr. James Chancey Bulpitt, and by her granddaughter, Miss Hannah Bulpitt. Mrs. Bulpitt continued to conduct the school most successfully until her death in 1842.

Miss Bulpitt then succeeded to the charge, but the school was closed in 1844, on Miss Bulpitt's marriage to Mr. Edward Roberson (Mellish p. 60).

Mellish says that Mrs. Bulpitt taught classes "in her own house." Does this mean that both Rev. and Mrs. Bulpitt owned separate houses? This confusion about houses will not go away because Mellish (p. 15) tells us that Rev. Bulpitt owned his house and that it was adjacent to the chapel. However, the manse for the chapel would not be built until 1821, when Rev. Stephen Bamford was appointed to the circuit.

On November 4, 1809, Rev. Bulpitt wrote to Rev. Dr. Clark about a severe lack of bibles and other books on the Island (Mellish, p. 14). It would be some years before newspaper ads appeared listing the arrival of book shipments from Great Britain.

Will you be so kind, dear sir, as to use your influence to get me some books to give the poor people here. I have been sometimes standing before a congregation of an hundred and fifty people in order to preach to them, and when I have asked for a Bible out of which to read the text, not a Bible could be obtained. This may appear very strange, but it is easily accounted for. The greatest part of the people are Loyalists who were stripped of all their property by the Americans. And I believe there are many here who have not had a Bible in their hands nor heard the Gospel for twenty-five years. The people have found it extremely difficult to get even food and raiment. Therefore if you can help them to a few Bibles and other books, I think it will be for the glory of God.

Our information on educational activities in Charlottetown in the early 19th Century is very slim. This story is told by Diane Morrow in the 26th number of the *Island Magazine*. In 1819 the first Sunday School on the Island was opened by Rev. Strong and was known as The Wesleyan Methodist Sunday School of Charlottetown. By 1826, 100 students were attending. Presumably the school activities took place in the chapel.

We learn from Mellish (p. 57) that “The Sabbath School in connection with the Church was held for many years twice on the Sabbath. In 1867 the morning school was discontinued.” This indicates that the Sunday School begun in the first chapel continued through to Isaac Smith’s 1835 chapel and on into the new brick church of 1864.

ANGLICAN EDUCATIONAL PROJECTS OF THE 1840s.

Saint Paul’s Anglican Church, in Queen’s Square, was the “official” church of the Island, recognising the monarch as the head of the Church. It was low church in orientation, deeply entrenched in the evangelical tradition of worship. Its hostility to Tractarianism was so powerful that a church built on Rochford Square in 1867 to accommodate an ever-increasing congregation, soon split away and became the High Church of Saint Peter’s with Catholic-inspired elements in its worship. This division still exists.

The story of Anglican educational endeavours in Charlottetown is to be found in Frank W. Jelks’s 1990 book, *The Parish of Charlotte and the Church of Saint Paul’s*. Early in its life Saint Paul’s Church became concerned with the education of the young. There had been Sunday School, perhaps spasmodically, since 1801, but now it was felt that a regular school was needed. It was decided to establish what was called at that time, an Infant School, to provide an elementary education. Isaac Smith, the great Methodist architect of the times, was invited to provide plans and in 1843 designed a single storey structure, 25 by 50 feet, that was placed on the south side of the wooden church, which Smith had also designed. Apparently, there were Gothic windows. A School Master and Mistress, George and Mrs. Hubbard, were imported from England and set up a school based on the Pestalozzi system. Johann Heinrich Pestalozzi (1746 – 1827) was a Swiss pedagogue who agitated for social and political justice. He was appalled that the bulk of Swiss working-class children were illiterate and set about to remedy this in schools he founded. His motto was “Learning by head, hand and heart”.



Detail from George Hubbard, "Panorama of Queen's Square" which shows an Isaac Smith architectural landscape of Province House, Saint Paul's Church and the Infant School with its cupola. Circa 1850, PEI Museum.

Hubbard was a very competent artist in the British topographical tradition and several wide-format watercolours of Charlottetown views survive in the PEI Museum Collection. One particularly dramatic painting shows Queen's Square in all its squalor after Province House was completed and the Infant School has been built.

This school had at its inception about 120 students. One wonders what the curriculum would have been like with such inspired pedagogy and the possibility of art instruction by the Master and Mistress. This is an area of Island art history that has not yet been explored.

The school was very successful, and it was enlarged, first in 1866, then in 1884-85, bringing its total dimensions to 60 by 70 feet. It closed in 1905 when the parish decided to build a much larger structure out of stone. The Methodist architect Chappell won the competition with his heavy rusticated stone design, which survives today as the Parish Hall, beating the proposal put forth by W. C. Harris.

Saint Paul's was also acutely aware of the need for a similar school in the west end of the city, especially a depressed area north of Euston Street in what the surveyor

Samuel Holland had designated as boggy ground. It was called, appropriately, “The Bog.” The name survives to this day. In 1848 a school was established by the Colonial Church and School Society on the west side of Rochford Street. Here destitute children were taught by an extraordinary school mistress, Sarah Harvie, who, only 16 years old, somehow sorted out the chaos that reigned, and established a highly-praised model school that lasted twenty years. By 1868 the school was too small and a larger building, called West End School, was constructed on Rochford and Euston in 1868, near the site where the huge West Kent School would be built a few years later.

THE 1848-49 WESLEYAN METHODIST CHAPEL AT CLIFTON



Detail of the map for Lot 48 from Meacham's *Atlas*, showing the location of the Clifton chapel in relation to the city. 1880.

Although not directly connected with the activities of the Methodist church in Charlottetown, the building activity that took place in Bunbury, across the river, is important to this story for two reasons. First, it shows how a few devout Methodists could go to great lengths to obtain a churchyard and build a chapel for worship. Secondly, the Clifton chapel itself, is a rare, little known, architectural survivor that shows us exactly what the primitive chapels going up in various communities around the Island looked like.

A few settlers in Lot 48 along the Hillsborough River in the Clifton/Bunbury area, were Methodists who belonged to the Charlottetown Circuit. Attending services at the various chapels in the city over the years was difficult, although, as the crow flies, the actual distance was very small. Communication in summer was by boat and in winter, on the ice. There would be long periods in the early winter and spring when communication was impossible.

Burials would always be a problem and so it was decided to set aside ground in the community to serve as a cemetery. James Kelly, whose property bordered the main road, donated a corner of his land, adjacent to that of William Farquharson, to be used as a cemetery. In Methodist records it became known as the Lot 48 Cemetery. The first four burials recorded are from 1836-39 (Kelly, p. 3).

By 1848 the congregation had grown to such a degree that it was no longer possible to meet in private homes and so money for a suitable chapel was raised.

The simple Methodist chapel was constructed during 1848-1849. The building's architect is not known however there is room for speculation. Perhaps architect Isaac Smith, who also happened to be a trustee of the Wesleyan Methodist Society in Charlottetown, contributed as he did when he supplied the plans for an enlargement of the Charlottetown Methodist Chapel in 1845. Smith and his Lot 48 brethren would have known each other well." ...

Original receipts show that the builder was fellow-Methodist and Charlottetown carpenter and joiner Christopher Smith. In late 1848, Christopher Smith bought 550 feet of pine planks and boards from Benjamin Chappell for the new chapel in Lot 48 for the price of 2 pounds, 4 shillings.

Methodist plasterer James Connell of Charlottetown completed the plasterwork. (Kelly, p. 6).

This chapel, only 22.5 by 24.5 feet, was considerably smaller than the first 1816 chapel on Richmond Street, which was 30 by 40 feet, and much smaller than Isaac Smith's 1835 chapel on Prince Street, which was 42 by 55 feet.



Clifton United Church, 2017. Photo by Reg Porter.



Interior of Clifton United Church, 2017. Photo by Reg Porter.

This chapel, unknown to most Islanders, is a precious remnant, largely architecturally complete, of the last period of building in a Georgian-derived classical style. The interior of the Clifton chapel is almost intact, as can be seen in the details of the main doorway, the trim around the door and windows and the simple pews with their very elegant mouldings and panels. The same quality of

work is seen on the low pulpit, which seems original. The only change that is not in accord with the style of the interior is the modern dark wood panelling installed in the chancel. It completely changes the original quality of the light, which would originally have flooded the whole space.

There is an interesting question of the style of the exterior of the chapel. It appears to be original with its broad eaves and panelled corner boards that form wide 14-inch pilasters. This is in accordance with the practice of Smith and other local builders in the 1820s to 1840s period and can also be seen in the vicinity of Charlottetown. In our studies of Isaac Smith's structures built of wood, we have come to associate a particular crowning element, not really a capital, on his pilasters, that Smith probably copied from John Plaw's 1811 Courthouse, when he worked on it in the 1820s, and then employed in his own buildings for the next twenty-odd years. It consists of a flat bracket, or modillion, that rests against the soffit. The effect is very elegant, and of an earlier taste. The crown moulding that Christopher Smith used to top the pilaster on the Clifton Chapel is typically classical and uses a quarter-round or ovolo moulding encased by narrow strips called fillets. This moulding was used for that purpose on most buildings for many years.



Top of the corner board at Clifton with quarter-round or ovolo moulding. The eave return is missing. This arrangement is basically the same as that used at the Crossroads chapel, except perhaps for the omission of the modillion.



The crowning element on top of the pilaster on the First Baptist chapel at Crossroads (1836), reflecting the practice favoured by Smith in his wooden buildings of placing a modillion against the soffit.

We will always have a lingering suspicion that Isaac Smith had a hand in the design of Clifton United, in spite of the frenzied pace of his last days on the Island. In May of 1848 he was finishing Province House and several other projects as well as preparing to move his family to Halifax. An attractive alternative to Isaac is Christopher Smith himself, who, working in the design vernacular of the day,

could easily have designed and built this simple but stylish chapel.

The Clifton Chapel has been in fairly-constant use as a place of worship since it was constructed. It is remarkable that in the 160 years of its existence it has never had electrical service, nor plumbing, nor a heating system other than a small stove.

THE GRAFTON STREET SCHOOL

Mellish tells us that in 1852 the Grafton Street School was opened. We do not know where this school was located on the street. A close study of the Lake 1863 map of Charlottetown did not reveal any information about its location, although Prince of Wales College is clearly marked. The school was big enough to accommodate 100 pupils and 12 teachers in 1860 (Maier, p. 30). It was also used in the evening for adult education. Could it have been in the large Athenaeum building on the northeast corner of Grafton and Prince?

In January, 1852, the Grafton Street School was opened. The officers of the new school for that year were: James Moore, Superintendent; William E. Dawson, Secretary; W. B. Dawson, Librarian. In the old school John Passmore was Superintendent; William Brown, Secretary; George R. Beer, Assistant Secretary and James R. Watt, Librarian. The Methodist Young Men's Mutual Improvement Society met for several years in the Grafton Street Schoolroom. The meetings were held once a week; papers on scientific and other subjects were read; and courses of lectures were sometimes given.

At a meeting of the congregation, held April 21, 1853, a Sabbath School Society was formed, and a constitution adopted. (Mellish, p. 57).

There seems to have been no more architectural activity among the Charlottetown Methodists until the cornerstone for the brick First Methodist Church was laid on May 25, 1863. It was opened on November 13, 1864.

CATHOLIC ENDEAVOURS IN PROVIDING PUBLIC EDUCATION

At this time the Catholic Church was continuing its intense work in the field of education when it opened Saint Dunstan's College in 1855. It was a huge wooden building designed in the 1840s by Isaac Smith. It survives today as the brick-

encased wooden core of Main Building. Although it sought candidates for the priesthood among its students, it gave a junior college classical education to all who enrolled in its programmes.

The question of government-funded public education in Charlottetown was to dominate the later part of the 19th Century. For the most part children were educated at schools set up in various buildings around the city that were organised and funded by the different religious denominations. These schools were small and the need for larger spaces to educate the ever-growing number of children in the city grew, as did the need for secondary education. The first major gesture to provide more-advanced instruction was made by the Catholics. The beginning was on a small scale in premises on the corner of Sydney and Weymouth Streets. There, a teaching order of nuns from Montreal, the Congregation of Notre Dame, set up a school for girls in 1857. It was very successful.

A few years later, in the winter of 1864, the energetic new Bishop of Charlottetown, Peter McIntyre, caused the large 1801 church at Saint Andrews to be moved twenty miles over the frozen Hillsborough to Charlottetown, where, after many adventures along the way, it was placed at what became known as 147 Pownal Street. There it became Saint Joseph's Convent and provided a Catholic education for Charlottetown children until it was absorbed by the city in 1916 and became known as the Rochford Square School (Rogers 1983, p. 192).

McIntyre believed passionately in education and in 1868 built, in his former parish, Tignish, a huge convent and boarding school in the late-Georgian style, next to the even bigger brick church he had built in 1860. Classes were open to the children of the village and boarders, even Protestant ones, came to this finishing school in the wilderness. This would set a trend in other communities across the island as similar convents, all staffed by the Sisters of Notre Dame, sprang up in Miscouche, Summerside, Rustico, Souris – and most significantly – in Charlottetown, when in 1870 the huge Notre Dame Academy was built overlooking Hillsborough Square.

This aggressive work of building large schools aimed primarily at the Catholic population of the city must have inspired the Methodists to begin a similar building programme. In 1871 they built the Wesleyan Methodist Academy, also called the Wesleyan Female Academy, on Upper Prince Street. It no doubt was in response to the building of the Catholic academy on Hillsborough Square.

The Wesleyan Methodist Academy, a large brick building on Upper Prince Street, erected at great expense, was dedicated with appropriate ceremonies

on the 9th January, 1871 . . . The first Board of Trustees of the Academy were R. Longworth, Simon Davies, T. W. Dodd, W. E. Dawson, G. R. Beer, W. Heard, W. C. Bourke. Mr. W. W. Anderson was the first principal, and Miss Robertson the first preceptress.

STAFF OF TEACHERS FOR 1871-2:

Wm. W. Anderson, Principal,
 Miss French, Preceptress,
 Professor Earle, Music Teacher,
 Miss Spencer, Assistant Music Teacher,
 Miss Reid, Teacher of Drawing, Painting, &c.
 Miss Narraway, Girls' Intermediate Department,
 Mr. Dickieson, Boys' Intermediate Department,
 Miss Mellish, Primary Department, and Division,
 Miss Coles, Primary Department, 1st Division,
 Miss Spencer, Infant Class.
 (Mellish, pp. 60-61)



The Wesleyan Methodist Academy, also called the Wesleyan Female Academy, built on Upper Prince Street in 1871. After being incorporated into the provincial educational system it became known as the Prince Street School. It is possible that the architect was Thomas Alley working in his favourite Italianate style. Photo from the internet.

The curriculum offered in this school would have had as its base the usual training in the “three r’s” but we see as well that there were teachers for music, drawing and painting. Their aim was to produce graduates with a basic education but also with a certain degree of culture. The Academy closed in 1876 when it became absorbed into the city educational system.



Detail from the Charlottetown map in Meacham's *Atlas*, 1880, showing location of the Academy and the new 1877 church, adjacent to the Elm Avenue Cemetery. The ensemble of church and school created a large Methodist enclave on Upper Prince Street.

In 1871 the Methodist church was ready to expand its mission into the north of the city and the Free Church of Scotland, which was empty, was rented as a mission church and school. This project was extremely successful (Mellish p. 56).



The Free Church of Scotland, on the northwest corner of Euston and Prince Streets, rented in 1871 to accommodate increasing congregations. PARO.

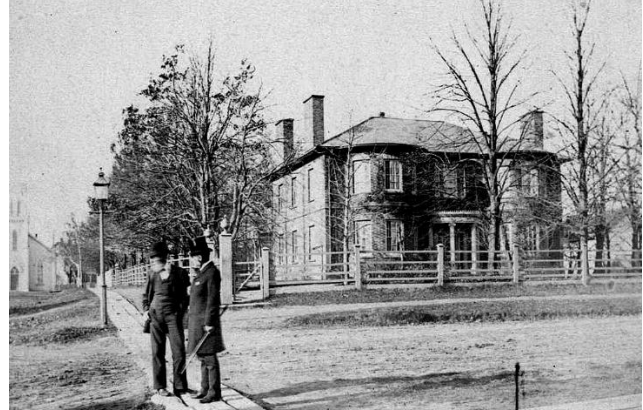

View along Prince Street showing the Free Church and Fairholm, the 1838-38 Regency-style brick home of the Hon. T. H. Haviland, later owned by prominent Methodist, Hon Charles Young. PARO.

UPPER PRINCE METHODIST CHURCH (GRACE METHODIST)

After only six years in the Free Church building, it was decided that a new and bigger church should be built on Prince Street. Thomas Alley once again designed a Gothic Revival church at what is now 55 Upper Prince Street and it was dedicated on October 14, 1877 (*Christian Guardian*, Toronto).

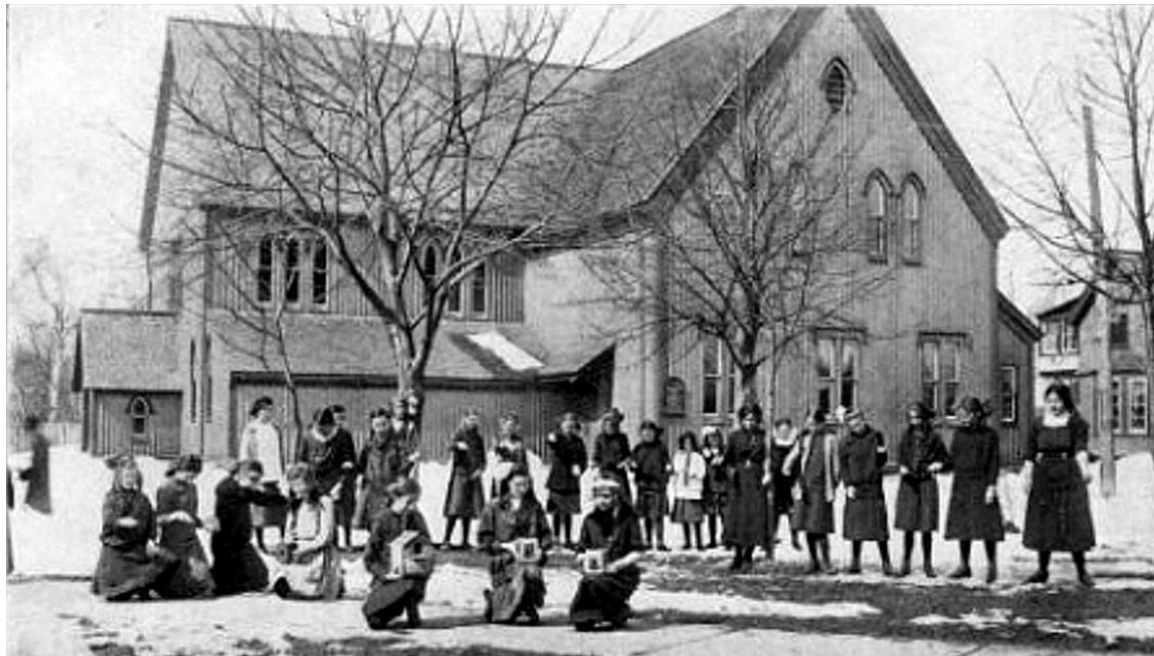

View of the enlarged (1884) Prince Street Methodist church (later renamed Grace Methodist) designed by Thomas Alley and built in 1877. Photo from internet, c. 1920s.

Thomas Alley is principally remembered for his large public buildings in the Italianate style, tall multi-storied buildings built out of brick, like the Union Bank on Great George Street (1872-73), the Provincial Law Courts in Queen's Square (1874-76), his home on Prince Street (1874-76) and the West Kent Street Public School in 1877. Alley was skilled in this style that was so fashionable in the 1870s and the buildings that survive are treasured parts of the cityscape. Alley's first major commission had been the First Methodist Church on Prince Street in 1863-64, and that was built in a Nonconformist Gothic Revival style probably copied from Canadian or American models popular at the time. His second attempt at Gothic Revival, the new church on Upper Prince, shows very little sensitivity for the style. We only know it from photos taken after 1884 when it was enlarged. It seems to be a mixed combination of elements, some Gothic, some Romantic, with board and batten siding, which was becoming popular once again, that resulted in a very undistinguished building.



Photo of Upper Prince Methodist church (Grace Methodist) showing the 1884 lateral wing added to the 1877 building. c. 1890. PARO.



View of chancel of Upper Prince Methodist church (Grace Methodist), date unknown. Photo from the Internet.

The interior is simple, even austere, with an elliptical arch framing the organ niche. The architectural trim is classically-inspired and there is little sign of Gothic detail. The austerity is softened by the pews, which curve around the sanctuary. The organ case is handsome, with simple rectangular panelling. The heavy pulpit has vaguely Gothic panelling. Spruce or Douglas fir wainscoting protects the lower portions of the plastered walls.

In 1883 the congregations of this church and the Bible Christian Church, across from the First Methodist on Prince Street, united and became a single congregation independent from First Methodist. This amalgamation resulted in a variety of names to be used over the years, resulting in confusion. On February 10, 1897, the name “Grace Church” was decided upon. Eventually, as times changed, and congregations declined, Grace Church joined with First Methodist during the ministry of Rev. R. G. Fulton in (1915-19) (Rogers 1964, p. 25-26).

In 1918 Grace Methodist church united with the First Methodist Church (now Trinity) and the building was offered for sale in the August 15, 1918 edition of the *Guardian*. It was bought and turned in a prestigious apartment building nicknamed “The Ritz.” It survives to this day at 55 Upper Prince Street.



Grace Church, as it exists today, as an apartment house at 55 Upper Prince Street.

A NEW GENERATION OF METHODIST ARCHITECTS TAKES OVER

A new architectural style entered the already well-represented collection of buildings by Methodists architects in the city.

The Grace Methodist Church Manse was designed for the congregation by prominent architects, Phillips and Chappell and constructed by builder, William Fraser, in 1886. It was the second manse for the congregation and was described by the 21 July 1886 edition of the *Examiner* newspaper as a “pretty, one and a half storey, hip roof structure containing ten rooms”.

The manse served the pastors of the Grace Methodist Church until

approximately 1918 when the congregation united with the First Methodist Church, or what is now the Trinity United Church on Prince Street.

...

Local directories reveal that a number of individuals called 63-65 Upper Prince Street home. In 1915, during the time that the Grace Methodist Church was still next door, Reverend F.H. Littlejohns, pastor, was listed as residing at 63-65 Upper Prince Street. However, by 1922, the house does not appear to be used by the church anymore, as it was inhabited by W.E. Fletcher, who lived there until at least 1928.

(<http://www.gov.pe.ca/hpo/app.php?nav=details&p=4752>).



The 1886 Chappell and Phillips Manse at 63 Upper Prince Street. It is in an austere, simplified Queen Anne Revival style, that was just beginning to become popular in Charlottetown

Charles Benjamin Chappell (1857-1931) was a Charlottetown builder who would become the dominant – and most eclectically prolific – architect of his generation. It is probable that he built more buildings for various purposes than any other architect. Chappell was very sensitive to changing styles and enthusiastically experimented with them in his various projects. In 1910 he designed a new brick manse for the First Methodist church, at 220 Richmond Street. That same year he built Hartz Hall next to the church. It was a massive multi-use building for church activities with so many contrasting and conflicting elements that one can only with difficulty call the style Romanesque Revival.

1898-99 – Kensington Hall

The Methodists were passionately interested in every aspect of the education of the young, starting with an introduction to the Scriptures, the mastering of basic skills in reading, writing and arithmetic and the acquisition of skills in various branches of the Fine and Domestic arts. Their efforts were largely concentrated in the eastern part of the city which had a large working-class population. One of their educational adventures took place in shabby quarters as far east as it was possible to go – on the largely undeveloped east side of Edward Street, between Euston and FitzRoy Streets. No image of the building survives.



Detail from Ruger's bird's-eye view of Charlottetown showing the empty Edward street, on the extreme right, where the 1898 Kensington Hall was constructed. Ruger lithograph, 1878.

Flora Smith Rogers give a bright description of this endeavour:

Again, we find this [the desire to educate the young] exemplified when the need arose in the Eastern part of the town and still another "Meeting Place" was established. It was in June 1898 that Kensington Hall was conceived and became a reality a year later. It stood on the east side of Edward Street, between Euston and Fitzroy Streets and was set apart by the "First" Church for special work as a Mission project. A dedicated band of workers made this Hall the centre of their activities on behalf of the people of that area. There a Sunday School was held and Home Department work carried on. Of

the splendid work of this Mission School perhaps the Cottage Prayer Meetings stand out as pre-eminent.

Kensington Hall itself was a rather crude structure, as it is recalled today, but it was the warmth and fervor of its workers, who rallied to the call of the people of that area, that gave it a special significance. This school numbered only ten officers and teachers and had on its roll one hundred and forty scholars. It was under the capable management of Miss Mary White, still remembered by many as the dressmaker, who used to spend days at a time in the homes, stitching and fitting the dresses and coats of many of the church children. There were few, if any, ready-made clothes in those days. ...

The school raised \$104.69 and reported 395 books in its library. The following year it was closed and its members attended Hertz Memorial Hall Sunday School (Rogers 1964, pp. 27-28).



The section of Edward Street today where Kensington Hall once stood. It is now a pleasant leafy enclave with 20th Century houses.

THE KINDERGARTEN AT THE ATHENAEUM BUILDING – 1895



The Athenaeum, also known as the Temperance Hall, the Philharmonic Hall and the Methodist School and Kindergarten. Its last days were spent, from 1924-68, as the home of the *Guardian* newspaper. It stood on the northeast corner of Prince and Grafton Streets. It dates perhaps from the 1840s or '50s. The architect is unknown. Photo from the Internet.

To this date we have been unable to identify the architect of this rather handsome building, reminiscent of the 1832 Central Academy just down the street, or the new Saint Dunstan's building, built in 1843-48. Nor do we know the date of the Athenaeum's construction, but its style speaks for itself. From a couple of existing photos, we can tell that the building had Greek Revival elements such as the massive cornice that runs completely around it under the eaves. Like Province House in its early stage, it had two pedimented ends and north/south frontispieces centered on the long sides which also had pediments. The pediments seem to have had semi-lunar windows in them. It probably also had massive corner boards, and all these elements add up to the Greek Revival style advocated by Isaac Smith. It would be very interesting if, during his frenetic building activities in the 1840s, Smith had produced yet another building that has slipped by our research into his work.

Rogers (1964, p. 29), as always, can be depended upon to give a lively and bright account of Methodist educational endeavours, and she does so in the case of the kindergarten that was, along with other facilities, established in this huge neoclassical building known variously as the Athenaeum, the Temperance Hall, or even the Philharmonic Hall.

Before the days of public schools the Methodists of Charlottetown were the leaders in building the Wesleyan Female Academy situated on Upper Prince Street. Under the leadership of Robert Longworth the school was built and operated until taken over by the city of Charlottetown and is known as Prince Street School. The funds received for this building were used to provide a Kindergarten and a school of music as a public service under the guidance of the Methodist Church. . . .

In the autumn of 1895, the Trustees of the Wesleyan Methodist School decided to open a Kindergarten and School of Music and the services of Miss Julia H. Sayre (afterwards Mrs. Edward Chandler), were secured for this work among the children. Miss Sayre was a teacher of rare ability and under her efficient management this venture met a real need in the town. Miss Lena Barrett was her assistant. This work was carried on in the Kindergarten building, which up until a few years ago housed the "Guardian" and "Patriot" newspapers, now Storey Electric Co. Ltd. The School of Music was then on the second storey of the building with a studio at each corner. There was also a commodious hall which was used for recitals and lectures. Miss Sayre and Miss Barrett had as their assistants Miss Daisy MacPherson and Miss Hunter. There was a total enrollment of 98 pupils in 1898. . . . The music of the choir was then, as always, a distinctive feature and the congregational singing under Professor Samuel N. Earle, was excellent and hearty. The Sunday School was large, prosperous and well organized with a staff of fifty-two officers and teachers and five hundred and thirty scholars in its three departments. In that year, 1898, the superintendents were John A. Moore, and James Paton [who in 1887 built a fine Romanesque Revival house at 241 Prince Street after a design by Phillips and Chappell].

Among other outstanding musical directors, through whose efforts the musical life of the community was built up, was W. Harry Watts, organist and choir director of the First Methodist Church. He was assisted in the teaching of music by Miss Fallie Baird, afterwards Mrs. Harry Weeks. . . .

The writer has many personal memories of Mr. Watts – the “Professor” as he was affectionately called. He had a dynamic personality and exceptional innate talent. His Friday afternoon music sessions at West Kent School are among the most treasured memories of his pupils. Sometimes he would bring his cornet with him and would play the air on this instrument, at the same time improvising a lovely, running accompaniment on the piano with his left hand. If the singing wasn't to his satisfaction, he would often stop playing and shout, “Tutti”, “Forte” or “Legato” and while we children didn't in the least understand the words, we always caught their meaning and responded to his wishes.

...

When the Kindergarten Building was sold to the “Guardian”, the School of Music and Kindergarten were removed to the basement of Trinity Church. A studio was added, where this work might still be carried on by the present Organist and Choir Director, Mr. Roy Mugford. ... Thus the Methodist tradition, now merged with the Presbyterian, continues as a teaching as well as a preaching people (Rogers 1964, pp 29-30).

From reading this account, from which we have quoted extensively, one gets an idea of the excellent cultural education the Methodists provided for the children of the congregation, starting in kindergarten and ending in the music schools. The children of the kindergarten must have heard the echoes of music every day. What an exceptional adjunct to their basic curriculum. What an atmosphere for learning! And for the students who were so fortunate to be in these music classes and choirs, how much enhanced their lives must have been by exposure and participation in so many forms of the arts. It adds up to a very fine education indeed.

After this time, the end of the 19th Century, there was no significant building activity, or use made of existing buildings, of any significance such as we have described in this chapter. More work would be done, of an ancillary nature, but outside the Methodist time span we have set for this manuscript.

Now the building and repair work was centered on the First Methodist church, where the interior was completely renovated and brought into the discipline of Gothic design. By 1955 a new and massive organ – still the joy of the congregation – was installed in a much-enlarged sanctuary.

So boundless was the faith and energy of the Methodists that, to achieve their religious and educational goals, they were prepared to move all around the city,

renting and building facilities as they were required. Their contribution to early education in the city was enormous as, joined by the efforts of the Anglicans and Catholics, the children of Charlottetown received rich and extensive instruction not only in the basics but in art and music as well. And all this was done before the City and the Province could be moved to provide these necessary rights to their citizens.

Epilogue

The story of the establishment of Wesleyan Methodism in Charlottetown, and all the building activity connected with it, is fascinating because it encapsulates the brotherhood's parallel striving with other missionary activity in many parts of the world. Charlottetown is a sort of microcosm where we can study all its aspects with pleasure, as we walk from site to site, over a very small number of city blocks. I called this book *The History of Methodism in Charlottetown* but could just as easily and meaningfully have called it *The Landscape of Methodism in Charlottetown*, because nearly all the land and buildings associated with the early congregations are today memories on historic maps, ultimately the product of the Enlightenment of the 18th Century. We can still visit all those spots, filled with the spirit of Methodism.

Just as in the rural perambulations of John Wesley, his brother, and their followers, throughout the English countryside to spread the word of God to the working classes, in private homes or in the open, so too did Benjamin Chappell, Wesley's disciple, bring Methodism to Charlottetown.

In a similar manner the early Methodists strived to build meeting houses where instruction in the Scriptures, and education for the young, were energetically pursued. We have seen that it took years from the time of Chappell's arrival in the city in 1778 until their first unsatisfactory chapel was opened in 1816.

Not content to worship God and teach His children in such unsuitable accommodations, by 1835 they were able to move into a much larger, and extremely elegant building, designed and built by one of their own, Isaac Smith, who changed the architectural face of Charlottetown and reached out far into other parts of the Island to provide the population with churches, courthouses and other forms of civic architecture. Smith's Greek Revival chapel soon became too small – a testimony to the phenomenal success of Methodism in meeting the spiritual and educational needs of the population – so that, in a very short time, it had to be enlarged twice. Again, the Charlottetown Methodists were following in the

footsteps of their English brethren as they strove to build finer and larger meeting halls and chapels in the neoclassical style of the times.

The Wesleyan Methodist congregations of Great Britain were endeavouring to shed the poor reputation forced upon them by the Anglican church of being dissenters and trouble-makers, by showing to the world that they were up-to-date citizens, now with a large membership that included the professional as well as the working classes. So too did the Charlottetown Methodists become leaders in all branches of society, and promoted, in their churches, their schools and their homes, the best, most up-to-date architectural practices of the day.

In England, an intense debate was taking place among Methodists and other nonconformist sects, about whether to adopt the newly-fashionable Gothic Revival style of architecture that was rapidly becoming the norm in most of the houses of worship being built. The Methodists felt uneasy about moving their worship into spaces that were derived from the traditions of Roman Catholicism, but being so progressive in their views and long-term goals, they found a way to adopt the basic principles of Mediaeval Gothic architecture and began building chapels in that style. These were adapted to the need for a large unobstructed preaching hall and subsidiary educational facilities.

When, on the eve of Confederation, Isaac Smith's wooden chapel, with all its extensions, became inadequate, there must have been much soul-searching and passionate discussion about what the new place of worship would be like. Gothic Revival won the day and two members of the congregation, Thomas Alley the builder, and Mark Butcher the furniture maker, were charged with producing a suitable Gothic design for the new chapel and its preaching hall interior. Neither men had the least qualification for this kind of challenge, but they produced a handsome brick church, based on widely-accepted North American models, and provided a vast preaching hall that, except for its white glass Gothic windows with their very fine tracery, bore little resemblance to the interior of a real Gothic Revival church.

For the rest of the 19th Century, and well into the 20th Century, the Charlottetown Methodists worked hard, on more than once occasion, to create a suitable Gothic interior in the new brick church that would respect the preaching hall yet incorporate such unheard-of excesses as pipe organs and stained-glass windows. Little by little all was achieved, and by the time of Unification in the 1920s, the church had a splendid Gothic-inspired interior. Work continued even after that time with the installation of a massive Casavant organ in 1955 and the filling in of

every possible opening – even where none existed – with stained glass that, in the end, represented one hundred years of evolution in that medium.

Today, only Clifton United Church at Bunbury remains as testimony to the early years of Methodist wooden architecture. In Charlottetown, Trinity United Church survives as a vibrant, active and community-oriented congregation with direct links to the times of Wesleyan Methodism. Constantly it celebrates its proud origins with yearly anniversary celebrations, and constantly it renews the fabric of the church with its many memorials to the piety of its members. It is a splendid place for the art-lover to visit, but most of all, it is a splendid place for the continuance of Christian worship and the practice of Christian charity based on the foundation of Methodism.

Appendix – The Trinity United Church Years

The change-over from the First Methodist Church to Trinity United Church brought the era of Methodism on Prince Street to an end. Our story stops here, but further work and embellishments on the brick church continued into the new era and are contained in the Methodist building. We continue our narrative into that period in this Appendix for the sake of the record.

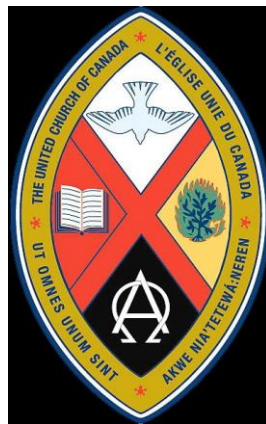

The acceptance of the formation of the United Church of Canada in Prince Edward Island was fraught with tension and argument. In the end, union prevailed.

In the mid-1920s Prince Edward Islanders vigorously debated the proposal to establish a new national Protestant church. The movement to merge Presbyterians, Methodists and Congregationalists into a new United Church of Canada produced intense conflict on the Island. Although it was ultimately successful, the process was probably more fractious in P.E.I. than in other parts of Canada, and even produced a minor constitutional crisis in Dominion-Provincial relations. Initially, the appeal of ecumenical ideology, the influence of clergy, and the promise of a solution to the problem of declining church memberships created by out-migration generated widespread support among Island Methodists and Presbyterians. But resistance intensified as church union loomed on the horizon. A tiny cadre of

dedicated anti-unionist ministers, aided by Presbyterian friends in high places, aroused loyalty to the threatened Presbyterian heritage and campaigned under the potent banner of religious freedom. This opposition was reinforced by the closeknit, traditional and largely rural nature of Island society; strong ties to the past, absorption in community affairs and a strong regionalism rooted in Maritime economic underdevelopment, all tended to undermine the appeal of a new Canadian national church. (Cameron, p. 109).

In June of 1925 the First Methodist Church united with Presbyterian members of the two congregations of the Kirk and Zion to join the United Church of Canada. This union was called Trinity United Church, “Trinity” having been chosen by the congregation.

[Rev. W. M.] Ryan through whose splendid co-operation and great reserves of graciousness and Christian tact and forbearance this union was accomplished, was joined in the church’s ministry by the Rev. E. H. Ramsay. From that year’s Report the following closing paragraph gives indication of this fine spirit:

“It is with sincere gratitude to God that we close the history of our first year as a United Congregation. From the very beginning we have had many evidences of His approval. The utmost harmony and goodwill have prevailed and as the months have gone by there has been a growing interest in every branch of the Church's work . . . and if with this new name “Trinity” there does but come a new spirit of consecration to the Church’s task, we shall make the future worthy of the best traditions of the past”. (Signed) W. M. Ryan, E. H. Ramsay.
(Rogers 1964, p. 37)

THE FOURTH STAINED GLASS PHASE – the 1930s

Since 1904 and the installation of the Longworth windows on either side of the chancel, no new stained glass windows had been installed in the church. The likeliest candidates for new projects were the four remaining aisle windows at the back of the church. We do not yet have specific dates but we know that the spaces were filled in 1929 and after, and after 1948.



North aisle window 2
War Memorial Window
 Luxfer Studios Ltd.
 Post 1929



South aisle window 2
Agony in the Garden
 Luxfer Studios Ltd.
 1929



North aisle window 1
The Three Marys
 Luxfer Studios Ltd.
 Post 1948



South aisle window 1
Solomon builds his Temple
 Luxfer Studios Ltd.
 1939

Trinity United seems to have abandoned McCauslands as their stained-glass maker of choice and turned to Luxfer Studios, also in Toronto, as all the windows

installed in that period are signed by that company.

The windows do not depart from the convention established by McCausland of fitting in the composition within the two lancets, separated by a wide centre post and enclosed by the frame. However there is not as much variety in composition as found in the McCausland windows. Like the Luxfer designs, McCausland could be very stiff and place unrelated figures in the two lancets, but on other occasions, he could open up the composition, like in “The Presentation in the Temple”, or “Jesus visiting Mary and Martha,” and create an astonishing sense of space in spite of the centre post.

There was a moment when a recommendation of the local architect, J. M. Hunter almost destroyed the overall order of the window spaces, when he proposed to remove the centre post in a 1939 window to celebrate the founding of the First Methodist Church. The inscription on the window reads, “To the memory of the men and women who in 1864 erected this church: the Congregation/ on the occasion of the 75 anniversary, November 12 1939, dedicated this memorial.”

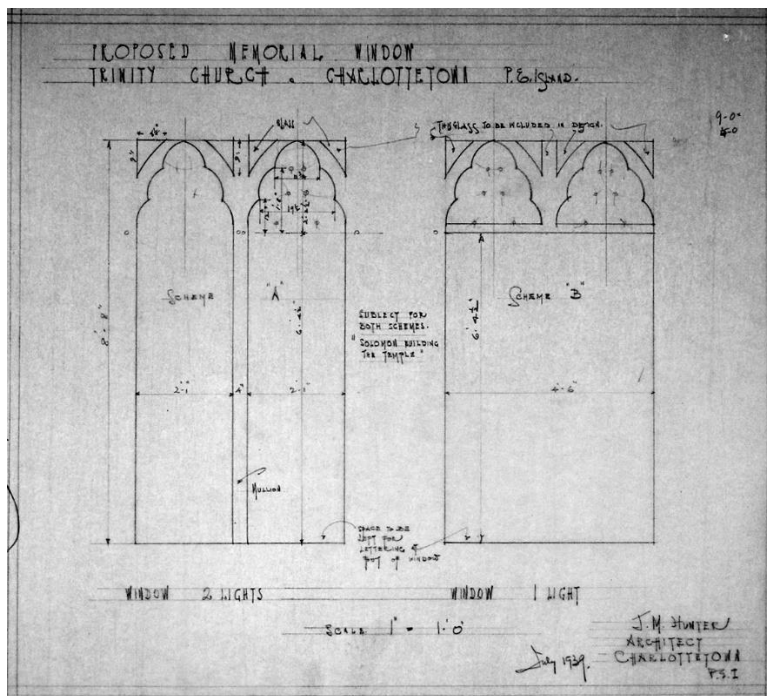

1939 Proposal by J. M. Hunter as to how the subject of the window, David instructing Solomon to build the Temple, should be presented, either as in the other windows, with the centre post running through the composition or, without the supporting post, as a single unobstructed view of the scene. Traditional practice prevailed. PARO.



Luxfer Studios of David instructing Solomon to build the Temple. Installed January 1939.

At some time still not determined, all the tops of the 14 side wall lancets that lit the galleries were filled with mostly identical coloured glass in a predominantly mauve colour. As part of this project the lower windows of the narthex or porch, behind the staircase, were filled with matching glass. No new glass would be installed until 1975.

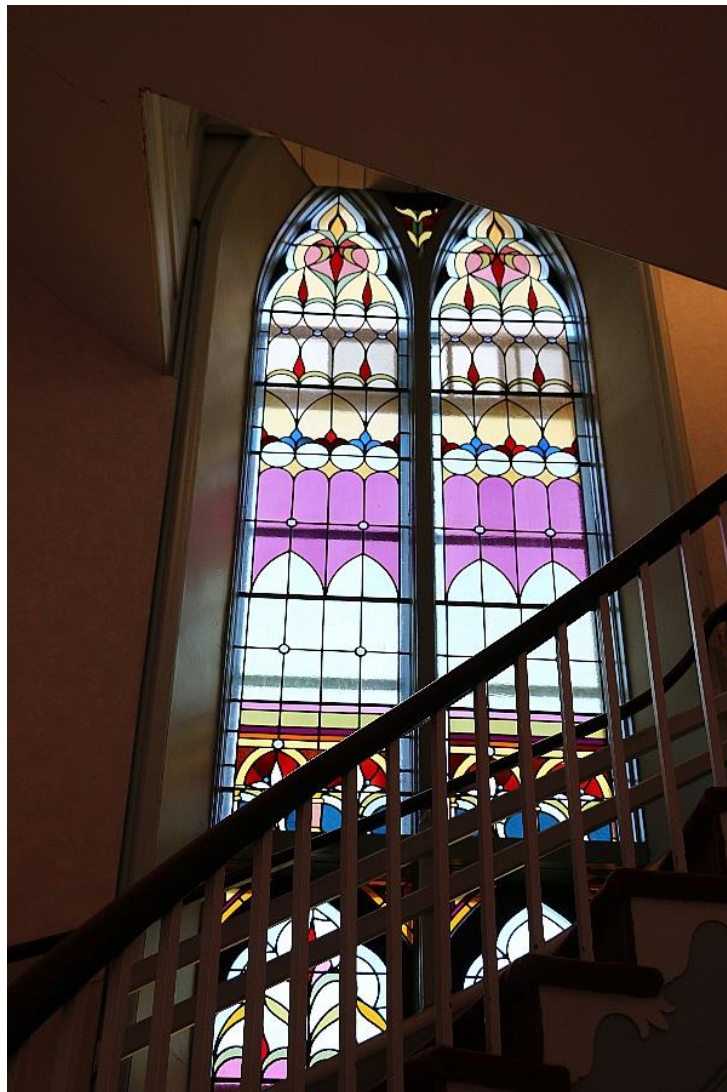

Following the stained-glass work, there seem to have been quite a few years of relative inactivity, probably because of the Depression. However, in 1931 the Board of Trustees report notes that at a meeting on June 6, they voted to give \$4000.00 to fix the Church organ which had been in disrepair for some time. The contract was given to the Woodstock Pipe Organ Builders. Other repairs to the church were postponed due to the cost of repairing the organ.

1927-47: THE URGE TO MAKE TRINITY UNITED GRANDER

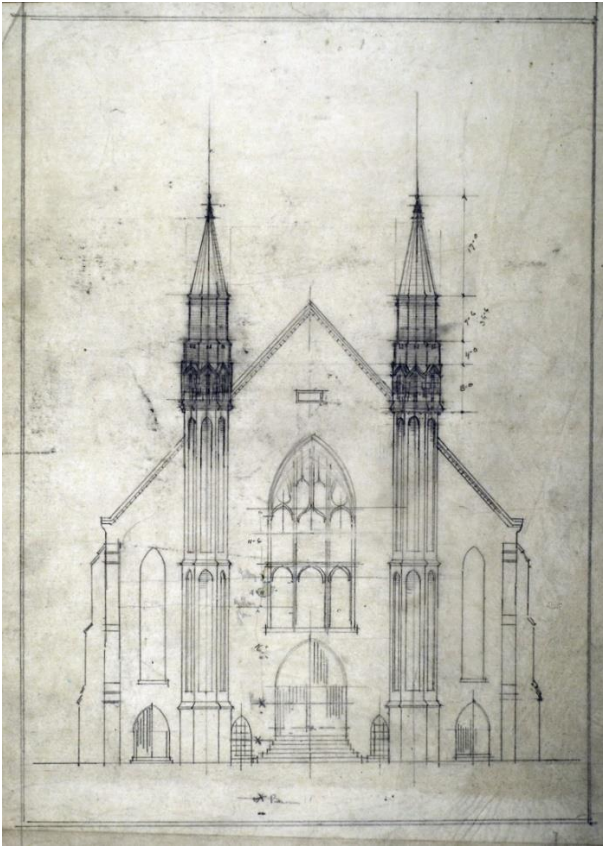

1920s proposal, possibly by Chappell and Hunter for alterations to the towers. This would have destabilised the design of the façade. PARO



1927 proposal by Chappell and Hunter creating a new top storey to match the gable end of the adjacent Hertz Memorial Hall. PARO

There is a curious surge in fantastical planning to renovate the façade of Trinity United Church in the 1927 to 1947 period. This is manifested in a series of drawings by prominent local architects preserved in local archives who seem to try and outdo each other by the extravagance of features and details they saw as necessary to improve the presence of the church in the city. No information has been discovered as to why these proposals were ever produced. Was it because Trinity United Church wanted to create a completely new image of itself now that it was no longer associated with the austere Methodists? Did influential members of the congregation imagine that the building was just too plain and something more elaborate was needed? The movement begins gently enough with a proposal (see above) to keep the church as built but erect extravagant tops to the turrets. The result, quite simply, makes the towers look top-heavy and unstable and its multiplicity of small design elements conflicts with the austere, yet architecturally

satisfying façade by Thomas Alley.

In the 1927 design by Chappell and Hunter the original architecture of the Alley chapel is allowed to survive as it was built, but with a massive crowing element that seems to try to link Trinity United with the heavy Romanesque-inspired architecture of Chappell's Hertz Memorial Hall. The effect is top-heavy and architecturally aggressive.

This all pales to insignificance in the next proposal presented by Chappell and Hunter. It is an expression of high ambition.

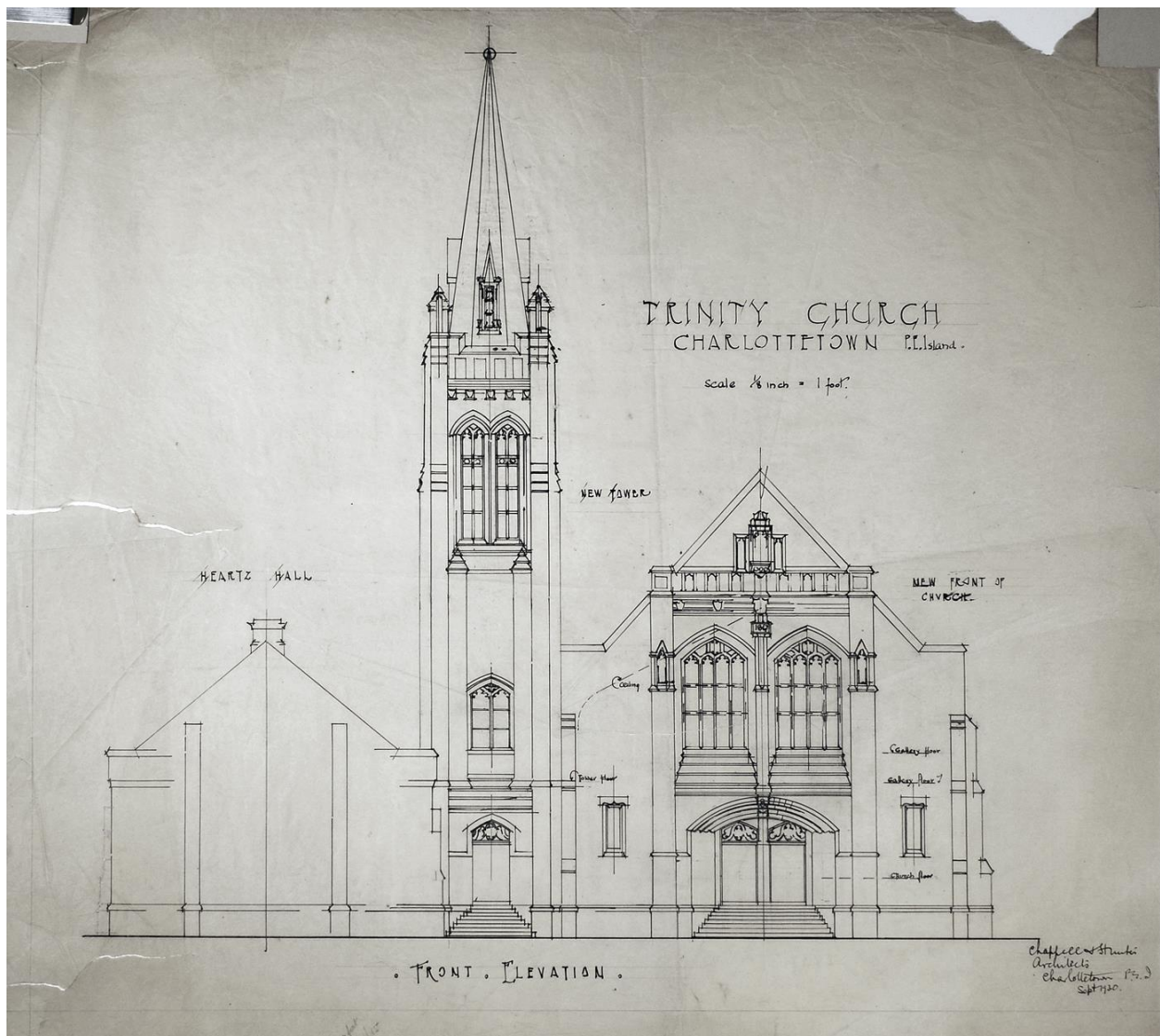

1930 Chappell and Hunter proposal for Gothic tower and spire and Tudor façade. PARO.

Of all the designs submitted in this period, this proposal seems like an assault on

the very essence of Thomas Alley's First Methodist Chapel. At the laying of the cornerstone in 1863, the then minister, Rev. John Brewster, said plainly,

It is not designed to eclipse, in beauty of architectural design, the other Protestant Churches of this City, nor outrival the conspicuous Roman Catholic cathedral. Allow me to say that the building about to be erected is to be a METHODIST CHAPEL, simple, plain, and exceedingly primitive. No tower or steeple will grace its ample proportions; no rich carvings in stone, nor fancy mouldings will attract the outer eye. Its peculiar excellence will be in its facility and convenience for preaching and bearing the Gospel of our blessed Lord and Saviour Jesus Christ.

Chappell and Hunter outdo themselves to contradict every stipulation laid down by the Rev. Brewster for the original chapel. They start by giving the church a profile similar to Hartz Hall, with the gables terminating on flat shoulders. By extending the profile of Hartz Hall to Trinity, Chappell appears to want to make it his own. The beautiful massive central window, so characteristic of early Methodist Gothic Revival architecture, a style that was so painfully and carefully adopted as a sign of progress, has been taken out and replaced by two Tudor Gothic windows in the Perpendicular style. The door has been widened and is no longer Gothic but rather capped with an elliptical tympanum filled with what appear to be sculptured details. The greatest surprise of all is the introduction of a tall mediaeval spire with what appears to be a belfry – all abominations to Reverend Brewster and his 1964 congregation!

Perhaps the most remotely disconnected proposal to change the west façade of Trinity United Church was put forward, in a very fine tinted drawing, by the architect Bone Blanchard, preserved in the Trinity United Archives. Nothing could be further from the intent of the original builders and from the Nonconformist style of the church itself. Blanchard seems to have sought his inspiration in France of the Catholic High Gothic period, with a massive northwest bell tower, flamboyant doorways and the whole façade brought forward so that the great west window, made more elaborate, is now in shadow. The doors have all been changed and appear to have sculptured ornament in the tympanum. To paste all these Catholic-inspired modifications to the austere Nonconformist façade of Alley's design shows a lack of sensitivity. Blanchard did well, in the end, to concentrate on his charming Colonial Revival domestic pastiches that dot the west end of the city. Some are truly stylish and adorn their streetscapes. He is affectionately remembered for this work.



1947 - Edward Stirling (Bone) Blanchard, Proposal for a new West Front at Trinity United Church, 1947, Trinity United Archives.

It is fortunate that none of these architectural fantasies was adopted. For the most part, Trinity United still bears the austere character of the First Methodist Church, so full of the theological thought of the time and the brave decisions of the Charlottetown Methodist Congregation to adopt the Gothic Revival for its new church.

In 1937, in a practical and necessary intervention to the fabric of the West Front, it was determined that the battlemented tops of the two turrets installed in 1902-03, were so far decayed that they had to be replaced with new materials. The prolific J. M. Hunter produced a drawing that appears to be the source of the present design of the turret tops.

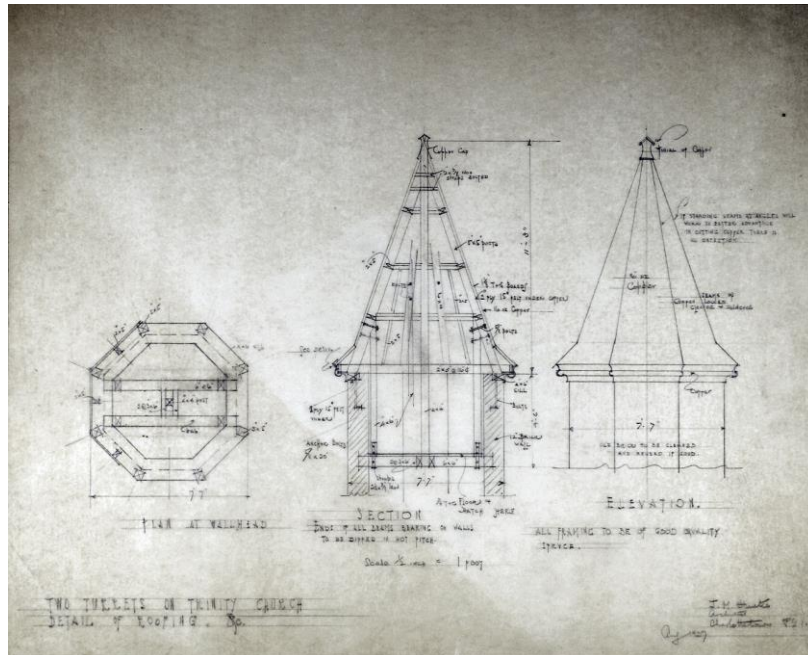

J. M. Hunter – Proposal for new tops to cap the turrets on the West Front. 1937. PARO.

Work seems to have progressed quickly and the present turret caps we see today were installed as a result. Hunter did not raise the turrets back to their original height by inserting the missing storey, nor did he try to design a spire that would approach the proportions of the original cast iron one, which gave the façade so much energy. Rather he chose squat caps that would keep the weather out. This is what we have today.



Hunter turret tops installed. c. 1940. Postcard.

No major repairs appear to have been required until 1951 when renovations were perhaps fortunately limited to the central door and steps. In the Trinity AGM report for 1951, a disbursement for 4,400 dollars for doors, steps and concrete work is recorded (Annual Report, 1951, p.5). On November 26, 1951 *The Guardian*, p. 5, reported that,

The newly constructed entrance doors and steps at the front of the church building were dedicated in a special ceremony conducted by the Minister, Rev. Mr. Ashford. Lt. Col. G. E. Full, Chairman of the Building Committee, presented a drawing of the improvements to be laid up as a permanent record.

Things were to change a few years later. In the 1954 opening report of the Annual meeting, it was noticed that

The action of the congregation at the Annual Meeting a year ago, in appointing a special committee to inquire into the condition of the church organ, and to make recommendations to the Official Board, began early in the year to bear fruit. A Contract was entered into with Casavant Frères of St. Hyacinthe PQ, to supply a new organ to be installed in the latter part of the year. The removal of the former organ early in the summer made the work of the organist and choir more exacting than usual.”

Soon the work of dismantling the old and installing the new was well in hand.

Work Progressing at Trinity Church

The work of dismantling the large organ at Trinity Church been completed except the console. The choir chairs will be removed this week and the work of building the steel and concrete foundation for the new 24-ton instrument will be undertaken by Schurmans who have the contract for this work as well as re-arranging the seating in the choir loft.

All the parts of the existing organ, numbering 2,000 pieces, will be shipped to Casavan[t] Brothers in Saint Hyacinthe, P.Q. where any serviceable parts will be incorporated in the new structure. The new organ will have 3,000 parts which will be assembled at the factory, tested and then dismantled for shipment here This operation is expected to take about six weeks or so.

The assembling of the new organ will begin in October and when another six weeks have passed it is expected to be ready for use. During the period of

time before the new organ can be used a piano is being substituted (*The Guardian*, Monday August 9, 1954, p. 2).

The Guardian, (Monday Nov 7, 1955, p. 5) reports the dedication and official opening of the new organ took place with a performance by Mr. George A. Thompson FRCO, who also unveiled a plaque in memory of the members of the congregation who died in WW II and Korea. A copy of this photograph in the Trinity United Archives records this event as taking place on February 20, 1955.



Casavant Organ. Photo labelled "Dedication of Trinity Memorial Organ, February 20, 1955." Trinity United Archives.

The new Casavant organ was quite magnificent. It had 2978 speaking pipes as opposed to those used for ornament in the case design. In all there are four separate organs housed in this massive case – the Great organ for volume, brilliance and tone, the Swell organ, housed in a louvered box for Romantic style soft/loud effects, the Choir organ filled with lighter solo stops and the great Pedal organ with its 16-foot church-shaking low notes and even a rarely-used 32-foot stop. As well there is a wide selection of couplers that permit combining sounds from the different organs to produce new effects. With all this variety this organ is perfect

for playing works of a variety of repertoires.

After the installation of the new organ, focus for the most part, moved away from Trinity United Church itself to other projects in the community. On November 1, 1960, Spring Park United Church was opened and dedicated (Bulletin, Blue Series 55, TUC Archives).

Education was a constant concern and in the same bulletin we find a description of plans to erect a new Christian Education Centre, and to incorporate a chapel and parlour into Hartz Hall. The cost was estimated to be around \$153 000.00 and the architect selected was Keith Pickard. The new Trinity Hall was opened and dedicated on November 14, 1965 as the new Christian Education Centre, located behind the church (Bulletin, Blue Series File #111, TUC Archives).



The 1965 as the Christian Education Centre designed by Keith Pickard. Trinity United Church Archives.

On October 28, 1969 Hartz Hall was destroyed by fire. It was not until 1971 that

the detritus was removed, and the site levelled. There had been damage done to the north side of the church and that was repaired at that time. This involved repairing the brickwork and replacing gutters and spouting at a cost of \$22 518.74, with \$16 000.00 of that amount from the Hannah Headley Estate (Annual Report 1971, pp 7-13, TUC Archives).

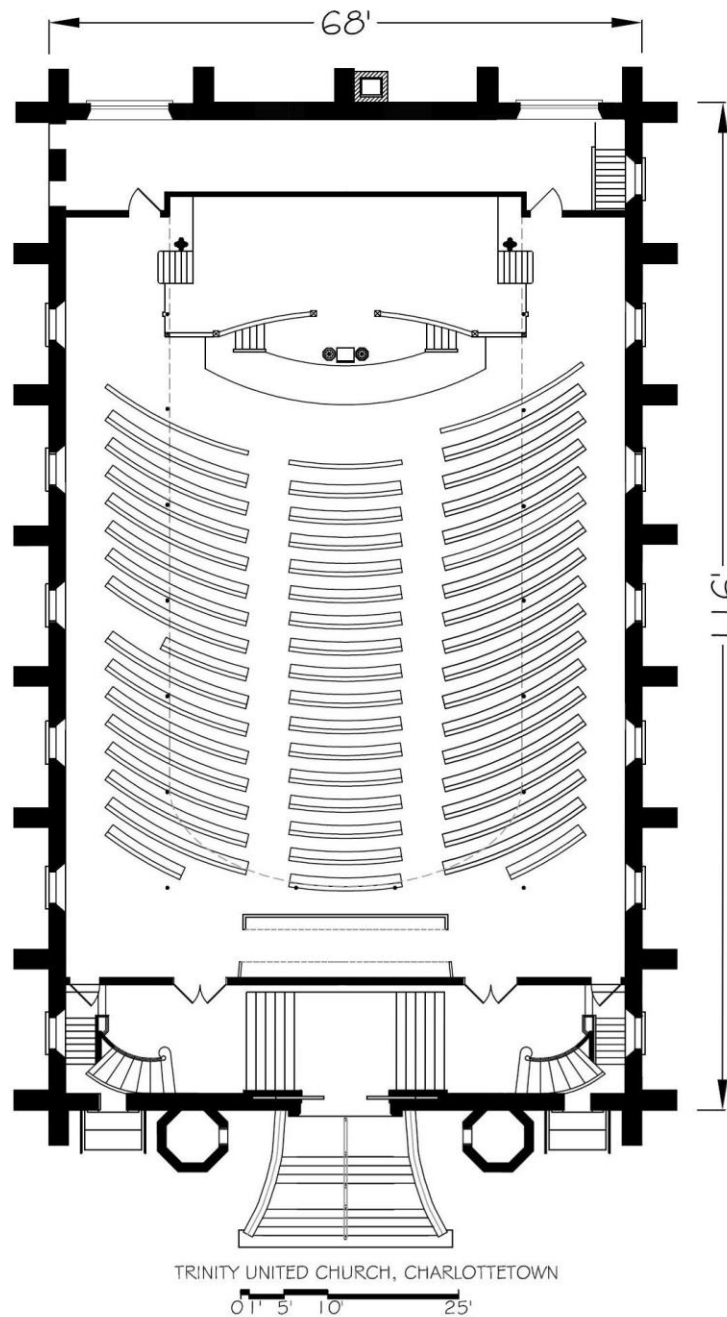

Plan of Trinity United Church after the various changes and renovations of the Twentieth Century. Plan by Carter Jeffery.

LAST THREE PHASES IN THE INSTALLATION OF STAINED GLASS

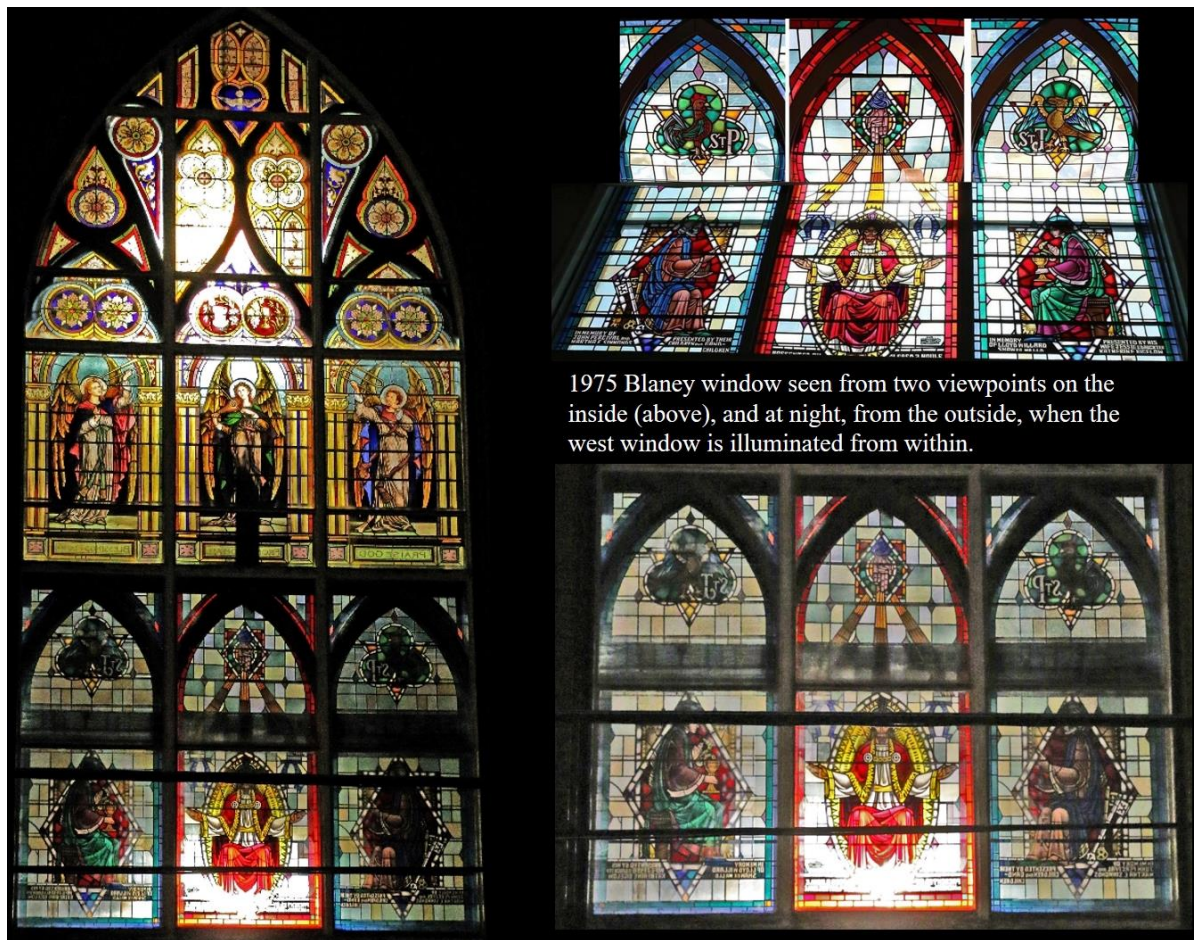

1975 Blaney window seen from two viewpoints on the inside (above), and at night, from the outside, when the west window is illuminated from within.

Night view of the great West Window and views from inside and out of the 1975 Blaney window. Photos: R. Porter

When, in the late 19th Century the great west window received the first stained glass in the church, only half of it, the upper part seen from the sanctuary, was filled with the splendid McCausland window. It was a Doxology in glass. The lower half of the tracery, 14 by 12 feet, was not visible from the sanctuary, except for a very narrow strip at the bottom of the Doxology window. The slope of the gallery and the backs of the pews blocked the top six feet of it. To see the bottom half, you had to go down to the porch or narthex and look above the main doorway into a space blocked by the thickness of the wall and the slant of the gallery floor.

For some reason which is not clear, in the early 70s it was decided to fill this large space with a fine window made by Paul Blaney in Saint John. It was a very traditional subject that just as easily could have been installed in a Catholic church.

It consisted of three vertical sections depicting Saint Peter with his symbol, the rooster, in the centre God in Glory, with the hand of the Father blessing him, and on the right, Saint John the Evangelist with his symbol of the eagle. The window, as a unity, could not be seen from the sanctuary and even today visitors must go to the back of the gallery and look behind the pews to see the upper symbols, then go down to the porch and see a portion of the part representing Christ and the disciples. It was installed in 1975.

To appreciate the full effect of the whole west window, completed in two phases about 75 years apart, one must wait until nightfall when the interior floodlights are turned on and the whole window is lit and visible from the street. It is the only way you can appreciate the 1975 window – through protective glass and in reverse!

Earlier plans for a chapel that was to be inserted in Hertz Memorial Hall had to be abandoned and in the early 1980s interest moved to the basement of the church.



South Window 3
Baptism of Jesus & Jesus Teaching
 Paul Blaney, St. John,
 1981



North Window 2
The Tetramorphs
 Burden and Hrabi
 1984



South Window 2
Jesus with Children & Healing the Sick
 Paul Blaney, St. John,
 1981



North Window 1
Various Religious Symbols
 Burden and Hrabi
 1984



South Window 1
Agony in the Garden & Resurrection
 Paul Blaney, St. John,
 1981

There, a chapel, and a parlour, separated by a wide hallway were carved out of this area. Both the chapel and parlour would soon provide spaces for eight more windows by Island and New Brunswick craftspersons. Above is the schema of the stained-glass windows, manufactured in the 1981-81 period, installed in the basement chapel.

The Paul Blaney windows were installed in the original basement window openings and are bright enough to bring useful light into the chapel space. The fact that there were no more window openings did not deter the church planners and two more windows were installed in the north wall using light boxes. These traditional style windows, by John Burden and Blaine Hrabi, in horizontal rather than vertical fashion, were installed in 1984. One interprets the Tetramorphs described in Revelation 4:1-8, while the other, also divided into four vertical sections, depicts traditional Christian symbols. Their warm colours conflict with the colder tonality of the Blaney windows.



Chapel Chancel window of Monogrammed Cross, designed by Henry Purdy and assembled by April FitzPatrick, 1991.

Around 1990 it was decided to install a large window, 4 ½ by 6 ½ feet tall, in an abstract design, behind the chapel altar table. Because of lack of vertical space in the basement, the window practically rests on the floor. Designed by local artist Henry Purdy and assembled by stained glass artist April FitzPatrick, the window is not traditional stained glass as in the earliest windows in the church, but an assemblage of modern opaque glass, depicting brilliantly the image of the Cross with a sacred monogram.

The parlour, on the north side of the basement, had room for only two stained-glass windows. Again, Burden and Hrabí were given the commission and in 1987, taking advantage of the heavy central beam of the tracery, produced four vertical windows depicting four of the Parables.

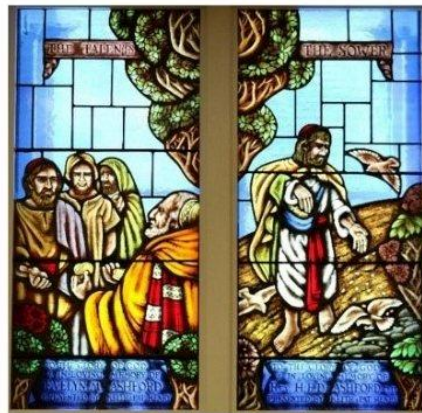

Parlour North Window 2
The Talents & The Sower
 Burden and Hrabí, Charlottetown,
 1987

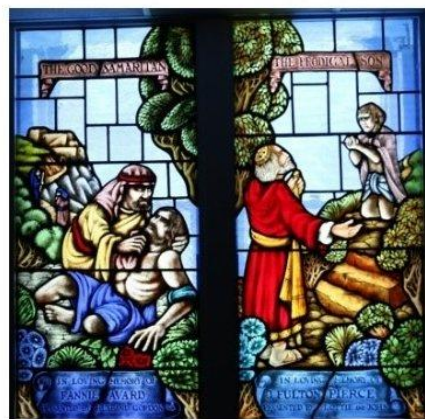

Parlour North Window 1
The Good Samaritan & The Prodigal Son
 Burden and Hrabí, Charlottetown,
 1987

From 1990-95 there was an extensive – and expensive – project to restore many of the stained-glass windows in the church. This work was mostly done by Burden Hrabí Stained Glass (Invoices 1990-1995, TUC Archives, File F-10).

It is indeed remarkable that the 1864 church was eventually filled to overflowing with stained and coloured glass windows that represent over one hundred years of Canadian stained-glass design and production. It is for that reason that, more than in any other church in the city, Trinity United is an essential place to go and study that evolution.

In 1999 the back area of the church property was tidied up in a major way when the building at 211 Richmond Street, behind the Manse, was demolished and the lot paved to make way for a parking lot (Annual Report 1999 p 16, TUC Archives). This created quite a large space leading right across the width of the block. It gives a surprising panoramic view of the east end of the church, the manse and the former school.



In 2001, after the importance of the school declined, the architect William W. Chandler designed a new major entrance to the church offices and other facilities. That is the Richmond Street entrance still in use today. It is a modest structure with three gothic arches framing shallow niches and flanking buttresses that imitate the brick and sandstone ones on the 1864 church.



Trinity United Church – the First Methodist Church – is a massive structure that is now 154 years old. Most of its original brickwork has survived and requires constant monitoring and attention so that water does not enter any part of the structure. Constant renovations are required and, indeed, are in progress as we write. This is likely to continue in the years to come.

The church built by Thomas Alley and Mark Butcher in 1863-64 is still recognizably their work. Despite extravagant proposals to modify the appearance of the west front, to satisfy the vagaries of fashion and taste, and except for its turret tops, which are one storey too short and lack a suitable cap, the church retains the massive, simple and noble presence on Prince Street. Perhaps in time the Congregation will see fit, as it has so energetically done in the past, to bring the church to its original appearance by restoring the turrets and spires so that they once again dominate their corner of the city.

Bibliography

Primary Sources

Betts, E. Arthur, *Bishop Black and his Preachers, Second and Enlarged Edition, Carrying the Story of Maritime Methodism from Its Beginnings to the Union of 1874*, Halifax: Maritime Conference Archives, Pine Hill Divinity Hall, Printed by the Tribune Press, Sackville, N.B., 1976.

Bowler, Rev. George, *Chapel and Church Architecture, with Designs for Parsonages*, John P. Jewett and Company, Boston, 1856.

Bremner, Benjamin, *An Island Scrapbook*, Charlottetown, 1932.

Bumstead, J. M., "Chappell, Benjamin" in *Dictionary of Canadian Biography*, vol. 6, University of Toronto/Université Laval, 2003.

Cameron, James, "The Garden Distressed: Church Union and Dissent on Prince Edward Island, 1925", *Acadiensis*, XXI, 2 (Spring 1992), pp. 108-131.

Cheetham, J. Keith, *On the Trail of John Wesley*, Luath Press Limited, Edinburgh, 2003.

Cherry, Bridget, ed., *Dissent and the Gothic Revival: Papers from a Study Day at Union Chapel Islington*, The Chapels Society, London, 2007.

Church, Leslie F., *The Early Methodist People*, The Epworth Press (Edgar G. Barton), London, 1948.

Clark, Kenneth, *The Gothic Revival: An Essay in the History of Taste*, John Murray, London, 1962.

Cousins, John, *New London: The Lost Dream*, Island Studies Press at the University of Prince Edward Island, Charlottetown, 2016.

Curtis, Thos., “Voyage to the Island of St. John’s,” in Harvey, D. C., Editor, *Journeys to the Island of St. John or Prince Edward Island: 1775-1832*, Macmillan, Toronto, 1955.

Dolbey, George W., *The Architectural Expression of Methodism: The First Hundred Years*, The Epsworth Press, London, 1964.

Goss, Warren W., *Methodists, Bible Christians and Presbyterians in Prince Edward Island – Campbellton – Miminegash*, Campbellton-Miminegash Fellowship Group in association with New Horizon’s Program of Health and Welfare Canada, 1984.

Heckbert, Alison Ann, “Carrying the Mails, 1763-1861”, *The Island Magazine*, No. 27 (Spring/ Summer, 1990), pp. 22-30.

Jelks, Frank W., *The parish of Charlotte and the Church of Saint Paul’s*, [Charlottetown], 1990.

Jobson, Rev F. J., *Chapel and School Architecture as appropriate to the Buildings of Nonconformists, particularly to Those of the Wesleyan Methodists: with Practical Directions for the Erection of Chapels and School-Houses*, Hamilton, Adams & Co., London, 1850.

Johnson, D. W., *History of Methodism in Eastern British America including Nova Scotia, New Brunswick, Prince Edward Island, Newfoundland and Bermuda*, The Tribune Printing Co., Ltd. Sackville, NB, [1920s?].

Johnstone, Walter, *A Series of Letters, descriptive of Prince Edward Island, in the Gulph of Saint Lawrence*, Dumfries: Printed for the author by J. Swan, 1822.

Kelly, Doug, *An Act of Faith – The History of Clifton United Church Stratford, P.E.I.*, unpublished manuscript, 2006.

Lewis, Michael J., *The Gothic Revival*, Thames and Hudson, London, 2002.

Lockerby, Earle, *Princetown Grammar School* (unpublished draft), 2018.

MacLeod, Ada, “The Oldest Diary on Prince Edward Island”, *Dalhousie Review*, Vol. 19, Issue 4, pp. 461-474, 1929/30.

Mair, Nathan H., collected and edited by, *Stories of the Wesleyan Chapel/ Charlottetown, P.E.I./ 1835-1864/ As Reported in Local Newspapers*, privately printed, Charlottetown, 2011.

McCausland, Andrew, of Robert McCausland Limited, Etobicoke, ON M8Z 2Z4, personal email communications, September-October 2015.

Mellish, John Thomas, *Outlines of the History of Methodism in Charlottetown Prince Edward Island*, George Haszard, Charlottetown, 1888.

Morrow, Diane, “A Little Learning: Early Education on Prince Edward Island,” *The Island Magazine*, No. 26, Fall/Winter, 1989.

Morrow, Marianne, “The Builder: Isaac Smith & Early Island Architecture”, *The Island Magazine*, No. 18, Fall/Winter, 1985.

Porter, Reginald, *The Stained-Glass Windows at Trinity United Church Charlottetown*, privately printed edition of 100 copies, Charlottetown, 2015.

Rogers, Flora Smith, “*Glimpses of Glory and Grace*” [cover title], Trinity United Church Charlottetown, 1809-1964, [title page], Trinity United Church Women, Charlottetown, [1964].

Rogers, Irene L., *Charlottetown: The Life in its Buildings*, Prince Edward Island Museum and Heritage Foundation, Charlottetown, 1983.

Rogers, Irene L., “Butcher, Mark,” in *Dictionary of Canadian Biography*, vol. 11, University of Toronto/Université Laval, 2003.

Smith, Henry, “Methodism in Charlottetown [First Paper]”, *The Prince Edward Island Magazine*, Vol. 4, No. 12, pp. 432-38, February 1902.

Smith, Henry, “Methodism in Charlottetown – Second Paper”, *The Prince Edward Island Magazine*, Vol. 5, No. 3, pp. 105-113, May-June 1903.

Smith, T. W., *History of the Methodist Church within the territories embraced in the late conference of Eastern British America*, 2v., Halifax, 1877–90.

Smith, H M Scott, *The Historic Churches of Prince Edward Island*, The Boston Mills Press, Erin, Ontario, 1986.

Stevens, Rev. A. A.M., *Memorials of the Introduction of Methodism into the Eastern States: Comprising Biographical Notices of its Early Preachers, Sketches of its First Churches, and Reminiscences of its Early Struggles and Successes*, Charles H. Pierce, Boston, 1848.

Trinity United Church Archives.

Trinity United Church Fonds, Public Archives and Records Office of P.E.I., Accession Number: 3295.

Printed Media

Christian Guardian, Toronto, 15 Aug 1877, 262, col. 5.

Examiner, Charlottetown, 21 July 1886.

Guardian, Charlottetown, 11 March and 22 August 1904.

Guardian, Charlottetown, 15 August 1918

Prince Edward Island Register, 8 January 1825.

Protestant and Ecclesiastical Witness, Saturday, May 30, 1863, p. 2 (transcribed by Reg Porter).

Protestant and Evangelical Witness, 19 November 1864.

Internet Sources

Alley, Thomas

<http://www.gov.pe.ca/hpo/index.php3?number=1019798>

Black, Rev. William,
G. S. French, "BLACK, WILLIAM (1760-1834)," in *Dictionary of Canadian Biography*, vol. 6, University of Toronto/Université Laval, 2003–, accessed December 2, 2016.

http://www.biographi.ca/en/bio/black_william_1760_1834_6E.html.

Barry and Pugin – Unitarian Chapel in Manchester

https://en.wikipedia.org/wiki/Upper_Brook_Street_Chapel,_Manchester

Chappell, Charles Benjamin (1857-1931)

<http://www.gov.pe.ca/hpo/index.php3?number=1023897>

Chappell 1910 Manse

https://www.google.ca/search?dcr=0&ei=h-9XWuPxOsaGjwSJw61w&q=methodist+brick+parsonage+-+charlottetown&oq=methodist+brick+parsonage+-+charlottetown&gs_l=psy-ab.3..33i160k1.20857.24076.0.24927.16.16.0.0.0.339.2201.0j11j1j1.13.0....0...1c.1.64.psy-ab..3.11.1914...33i21k1.0.oeftABezd6k

Cornerstones

<https://en.wikipedia.org/wiki/Cornerstone>

Helmsley Primitive Methodist chapel, built 1812

http://www.myprimitivemethodists.org.uk/page/helmsley_primitive_methodist_chapel?path=0p9p27p

Karn Organs

<http://www.thecanadianencyclopedia.ca/en/article/karn-piano-co-ltd-emc/>

Smith, Isaac

<http://www.gov.pe.ca/hpo/index.php3?number=1020278>

Smith, Isaac - Biographical Dictionary of Architects in Canada 1800-1950

<http://dictionaryofarchitectsincanada.org/node/1263>

Secondary Sources

Child, Mark, *Discovering Church Architecture*, Shire Publications Limited, Oxford, 2012.

Clowney, Paul & Tessa, *Exploring Churches*, William B. Eerdmans Publishing Company, Grand Rapids, Michigan, 1982.

Ferguson, George, *Signs & Symbols in Christian Art*, Oxford University Press, New York, Reprinted 1967.

Hall, James, *Dictionary of Subjects and Symbols in Art*, Icon Editions, Harper & Row, Publishers, New York, Revised Edition 1979.

Lee, Lawrence; Seddon George; Stephens, Francis, *Stained Glass*, Crown Publishers, Inc., New York, 1976.

McNamara, Denis R., *How to Read Churches: A crash course in ecclesiastical architecture*, Herbert Press, London, 2011.

Metford, J. C. J., *Dictionary of Christian Lore and Legend*, Thames and Hudson, London, 1983.

Sill, Gertrude Grace, *A Handbook of Symbols in Christian Art*, Collier Books, a Division of Macmillan Publishing Co., Inc., New York, Second Printing 1979.

Sloan, Samuel, Architect, *City and Suburban Architecture; containing numerous designs and details for Public Edifices, Private Residences, and Mercantile Buildings*, J. B. Lippincott and Co., Philadelphia, 1859.

Webber, F. R., *Church Symbolism: An Explanation of the More Important Symbols of the Old and New Testament, the Primitive, the Mediaeval and the Modern Church*, Second Edition Revised, Gale Research Company, Detroit, 1971.

Stained Glass Manufacturing Techniques

These three short videos called “The Eternal Art of Stained Glass” from the Robert McCausland Limited website explain how stained-glass windows are made, from concept to installation. They can be found at this link:

<http://www.eternalglass.com/videos>

Stained glass: history and technique

<https://www.khanacademy.org/humanities/medieval-world/latin-western-europe/gothic1/a/stained-glass-history-and-technique>

